



Ursinus College

Digital Commons @ Ursinus College

Pre-calculus and Trigonometry

Transforming Instruction in Undergraduate
Mathematics via Primary Historical Sources
(TRIUMPHS)

Spring 3-2017

A Genetic Context for Understanding the Trigonometric Functions

Danny Otero

Xavier University, otero@xavier.edu

Follow this and additional works at: https://digitalcommons.ursinus.edu/triumphs_precalc

 Part of the [Curriculum and Instruction Commons](#), [Educational Methods Commons](#), [Higher Education Commons](#), and the [Science and Mathematics Education Commons](#)

[Click here to let us know how access to this document benefits you.](#)

Recommended Citation

Otero, Danny, "A Genetic Context for Understanding the Trigonometric Functions" (2017). *Pre-calculus and Trigonometry*. 1.

https://digitalcommons.ursinus.edu/triumphs_precalc/1

This Course Materials is brought to you for free and open access by the Transforming Instruction in Undergraduate Mathematics via Primary Historical Sources (TRIUMPHS) at Digital Commons @ Ursinus College. It has been accepted for inclusion in Pre-calculus and Trigonometry by an authorized administrator of Digital Commons @ Ursinus College. For more information, please contact aprock@ursinus.edu.

A Genetic Context for Understanding the Trigonometric Functions

Daniel E. Otero*

July 23, 2019

Trigonometry is concerned with the measurements of angles about a central point (or of arcs of circles centered at that point) and quantities, geometrical and otherwise, that depend on the sizes of such angles (or the lengths of the corresponding arcs). It is one of those subjects that has become a standard part of the toolbox of every scientist and applied mathematician. It is the goal of this project to impart to students some of the story of where and how its central ideas first emerged, in an attempt to provide context for a modern study of this mathematical theory. Today an introduction to trigonometry is normally part of the mathematical preparation for the study of calculus and other forms of mathematical analysis, as the trigonometric functions make common appearances in applications of mathematics to the sciences, wherever the mathematical description of cyclical phenomena is needed.

If you work through this entire project, you will encounter six milestones in the history of the development of trigonometry. Our journey will span a vast interval of time, from some unidentifiable moment dating as far back as about 1000 BCE, to roughly the year 1500 CE; and we will consider developments of the subject that took place in many different parts of the world: in ancient Mesopotamia; in Hellenistic Greece and Roman era Egypt; in medieval India; in central Asia during the height of Islamic science; and in Renaissance Europe. The term “milestones” is quite appropriate, since we are only touching on a few moments in a long and complex history, one that brings us just to the edge of the modern scientific era in which we now live.

More specifically, we will look at the following episodes in the development of the mathematical science of trigonometry:

- the emergence of sexagesimal numeration in ancient Babylonian culture, developed in the service of a nascent science of astronomy;
- a modern reconstruction (as laid out in (Van Brummelen, 2009)) of a lost table of chords known to have been compiled by the Greek mathematician-astronomer Hipparchus of Rhodes (second century, BCE);
- a brief selection from Claudius Ptolemy’s *Almagest* (second century, CE), in which the author shows how a table of chords can be used to monitor the motion of the Sun in the daytime sky for the purpose of telling the time of day;
- a few lines of Vedic verse by the Hindu scholar Varāhamihira (sixth century, CE), containing the “recipe” for a table of sines as well as some of the methods used for its construction;

*Department of Mathematics, Xavier University, Cincinnati, OH, 45207-4441; otero@xavier.edu.

- passages from *The Exhaustive Treatise on Shadows*, written in Arabic in the year 1021 by Abū Rayḥān Muḥammad ibn Aḥmad al-Bīrūnī, which include precursors to the modern trigonometric tangent, cotangent, secant and cosecant; and
- excerpts from Regiomontanus' *On Triangles* (1464), the first systematic work on trigonometry published in the West.

Students who wish to learn more about the history of trigonometry are recommended to consult Glen van Brummelen's masterful *The Mathematics of the Heavens and the Earth: the early history of trigonometry* (Van Brummelen, 2009), from which much of this project took inspiration.

1 Babylonian sexagesimal: measuring angles and arcs

Our story starts *way, way* back, during the second millennium BCE, when Assyrian scholars in Old Babylonia¹ produced the oldest known records of celestial phenomena, on a collection of clay tablets known as the *Enuma Anu Enlil*. These tablets contain long lists of astrological omens referring to lunar and solar eclipses, or the locations of the planets within certain constellations at certain times. They were compiled over many centuries during the second and first millennia BCE in Babylonia and *they herald the beginning of science as the systematic study of the natural world*. Ironically, these oldest records more properly pertain to *astrology* than to mainstream modern *astronomy*. Astrology is a subject now discredited in Western science as providing untestable (and therefore, unscientific) explanations for the movements of heavenly bodies; it bases explanations of the motions of the stars and planets on the actions of supernatural forces or divine entities with whom these bodies are associated, and it discerns from these motions why certain people enjoyed fortune while others were ill-fated. It also identifies auspicious times for adherents to engage in future actions. Astronomy, on the other hand, explains how the heavens move by means of natural physical forces and, by and large, ignores the impacts they make on human actions and social concerns.

The *Enuma Anu Enlil* mark the earliest documents in a long Babylonian tradition of keeping track of the motions of the stars and planets (North, 1994). From these records, they recognized the following gross features of the motions of heavenly bodies:

- that the shape of the sky was that of a huge sphere, the *celestial sphere*, which rotated about the Earth roughly once a day, carrying the fixed lights of stars along with it;
- that the stars were arranged in patterns called *constellations*, named for fanciful animals, objects, and mythological figures, and which helped astronomers to gain their bearings and locate other stars and planets;

¹Babylonia is the name given to the valley between the Tigris and Euphrates rivers (present day southern Iraq and southwestern Iran), centered on the ancient city of Babylon, which was an important political and cultural center of the region during this era. A number of human cultures flourished there, notable among them that of the Sumerians in the third and second millennia BCE – the period of Old Babylonia; and the Assyrians, whose era of most powerful political control in the area dates from the tenth through sixth centuries BCE. These were followed by the ascendancy of a New Babylonian civilization. This last culture, also known as Chaldean, is familiar to Biblical scholars, as it flourished in the sixth and fifth centuries BCE, its most famous ruler being Nebuchadnezzar, who conquered the Hebrew kingdom in Jerusalem in 587 BCE and razed Solomon's Temple.

- that the movement of the Sun around the Earth produced a daily cycle close to but different from that of the celestial sphere; and that its motion across these background stars produced a yearly cycle that governed the seasons;
- that the motion of the Moon across the sky produced a monthly cycle, and that its path was close to but different from that of the Sun;
- that because of this, the Moon came between the Sun and the Earth once in a great while to produce a dramatic *solar eclipse*; and that somewhat more frequently, the Earth blocked the light of the Sun on the face of the Moon, causing a *lunar eclipse*; and that these events occurred with a complicated but identifiable cyclical frequency;
- that the Sun, Moon, Mercury, Venus, Mars, Jupiter, and Saturn – all the *planets* visible to the naked eye² – moved within a narrow band around the sky; the constellations found in this band were collectively called the *zodiac*³.

Extensive astronomical records required the ability to locate objects in the sky and note when and how often they reached these positions. For this purpose, a numeration system was needed to represent the quantities encountered when measuring distances between objects, angles of inclination along circles, or times between events. Babylonian astronomers evolved a powerful number system to do this which emerged from the simultaneous use of at least two different metrical systems, one with units of 10 (and possible subunits of 5) mixed with one or more other systems with units of 6 (and possibly also larger units of 12). These systems combined to create what is known as *sexagesimal numeration*, based on units of size 60. Objects were counted in groups of 10 until one reached 60 objects; these would then constitute one larger unit. For numbers larger than 60, the same grouping process would be used with the larger units to produce even larger units. For instance 250 objects would be reckoned as 4 large units of 60 smaller units each, plus an additional 10 of the smaller size. This could also be done with small fractional parts, since each small unit could be split into 60 smaller parts.

For example, the number we represent as $2\frac{3}{4}$ would be reckoned in this system as 2 units with 45 smaller units, representing three-fourths, or 45 sixtieths, of the original unit.

Sexagesimal numeration shares important features with the decimal system we employ today, wherein we count units from 1 through 9 with single digits, tens using a second digit between 1 and 9 written to the left of the ones digit, hundreds with a third digit of the same type to the left of the tens digit, etc., all the while using 0 as a placeholder when no objects of the corresponding magnitude (units, tens, hundreds, ...) are used. Decimal numeration requires just these ten symbols, the digits 0, 1, 2, ..., 9, to represent any number. This kind of system is called *positional* because the positions of a digit within a specific numeral indicate what size units they represent: ones, tens, hundreds, and so on, with larger powers of 10 off to the left to count larger and larger groupings of units; similarly, tenths, hundredths, thousandths, and even smaller fractions of units (the negative powers of 10) appear to the right of the units digit to measure finer and finer parts of units. In addition, we use a decimal point to separate values of units from their fractional parts. For instance, the number we called $2\frac{3}{4}$ above is written in decimal form as 2.75 because the 2 represents two units, the 7 seven

²The word *planet* comes from the Greek *planetos* = English *wanderer*.

³From the Greek *zodiakos* = English *little animals*.

tenths of these units, and the 5 five additional hundredths (that is, tenths of tenths). That is, in decimal form $2.75 = 2 \text{ units} + 7 \text{ tenths} + 5 \text{ hundredths} = 2 + \frac{7}{10} + \frac{5}{100} = 2\frac{3}{4}$.

In the same way, this number would be represented in sexagesimal form as 2 units + 45 sixtieths, requiring only two sexagesimal digits. Note that 45 is a *single sexagesimal digit*, as is any number of units less than 60, in the same way that any number of units less than 10 corresponds to a *single decimal digit*.⁴

Throughout this project we will adopt the following convention for writing numbers in sexagesimal form: such representations will be expressed as a sequence of sexagesimal digits enclosed between brackets [], where we use a semicolon (;) to represent the sexagesimal equivalent of a decimal point: it will be used to separate units from sixtieths (in the same way that the decimal point separates units from tenths). Thus,

- $2\frac{3}{4}$ is written in sexagesimal form as [2; 45];
- 78 is written as [1, 18];
- 4.0075 is written as [4; 0, 27]; and
- 4800 is written as [1, 20, 0].

However, note that we are using familiar *decimal* forms for the *sexagesimal* digits 0, 1, ..., 59. Thus, the number 78, written above in sexagesimal form as [1, 18] has a two-digit sexagesimal form: remember, 18 is a *one-digit* sexagesimal number!

Task 1 Verify that the numbers 78, 4.0075, and 4800 have the sexagesimal representations identified above. Explain how you know that these representations are correct.

Imagine for a moment that you live in ancient Babylon, with no knowledge of modern science and none of the conveniences of modern life – no electric lighting at night, no ability to transport yourself across great distances quickly by car or airplane, no smartphone to connect you to the rest of the world, no standard time from a watch or clock to tell the time of day. Your environment is very likely restricted to a small portion of the earth near where you were born. Your experience of the world includes the reality that when the Sun sets, your life is dominated by darkness, punctuated by occasional firelight – and the beauty of the stars and the Moon!

You are used to the fact that the Sun moves across the background stars of the sky over the course of a year, taking just a bit over 360 ($= 6 \times 60$) days to make one full circular orbit around the sky. You know this because the same constellations of stars are visible in the night sky – at precisely the *opposite* location to the Sun in the heavens – at the same time every year; you know that certain constellations are summer constellations while others are winter constellations. That is, the Sun moves along a circular path against the background stars, called the *ecliptic circle*, about one 360th of its full annual course every day.

⁴This is the hardest thing to get used to for those new to sexagesimal numeration. Decimal numeration is such an ingrained part of how we understand numbers that it is difficult to recognize that the same number which we write using two or more decimal digits can also be written using fewer sexagesimal digits. But this is quite often the case: because 60 is a larger base than 10, the same number tends to be expressible using fewer sexagesimal digits than decimal digits.

These considerations made it convenient for Babylonian astronomers to divide the circular path of the Sun into 360 parts, a measurement system that has endured to the present day. We call these parts of a circle *degrees*. If degrees needed to be further subdivided, one would use units corresponding to sixtieths of a degree, today called *minutes*.⁵ If further accuracy was needed, one could use an even smaller unit called the *second*⁶, corresponding to sixtieths of a minute (or one 3600th of a degree, since $3600 = 60 \times 60$). These angular units of 1° (degree), $1'$ (minute), and $1''$ (second), became the standard way to measure along circles for Babylonian astronomers, and almost 4000 years later we use this same system. For instance, an angle measure of 4.0075° is the same as an angle of measure $4^\circ 0' 27''$ (see Task 1).

Task 2

- Mark a point in the center of a blank sheet of paper and label it O . Then, preferably with a compass, draw a large circle centered at O . Mark a point on the circle at the “3 o’clock” position and label it A . Set your compass to the length OA of the radius of the circle, then, starting at A , mark off points B, C, D, \dots around the circle so that each of the segments $\overline{AB}, \overline{BC}, \overline{CD}, \dots$ has the same length OA .⁷ You should find that eventually, the sequence of points A, B, C, \dots comes back exactly to A . Now draw in the line segments $\overline{AB}, \overline{BC}, \overline{CD}, \dots$ around the circle. What shape have you now drawn within the circle? Be as specific as you can about describing this figure.
- Using a very light pencil line, connect the vertices of your figure through the center O to the points opposite them across the circle (which also happen to be points of the same figure). These lines partition the figure into smaller figures. Describe in detail what the shapes of these smaller figures are. How can you tell?
- How large, in degrees/minutes/seconds, is the angle spanning the arcs from A to B , B to C , C to D , etc.? Assuming that the radius of the circle has unit length, how long are $\overline{AB}, \overline{BC}, \overline{CD}, \dots$?
- Again using a light pencil line, draw in the diameters of the circle which are perpendicular to the segments $\overline{AB}, \overline{BC}, \overline{CD}, \dots$ of the figure. These diameters will strike the circle in another set of points which bisect the arcs between A and B , B and C , C and D , etc. Label these points A' (between A and B), B' (between B and C), C' (between C and D), etc. If we now connect consecutive points around the circle to create segments $\overline{AA'}, \overline{A'B}, \overline{BB'}, \dots$, what shape do we now produce inside the circle? And how large is the angle spanning these shorter arcs around the circle, from A to A' , A' to B , B to B' , etc.?
- Finally, let P be the point where the diameter having endpoint A' cuts side \overline{AB} of the original figure. What are the angles in the triangle OPA ? Use the Pythagorean theorem to determine the lengths of the sides of triangle OPA .

⁵From the Latin phrase *partes minutae primae* = English *first small parts*.

⁶From the Latin *partes secundae minutae* = English *second small parts*

⁷In this project we use the widely adopted convention of referring to line segments using an overscored pair of letters: \overline{XY} is the line segment whose endpoints are denoted X and Y . We use XY (without the overscore) to refer to the numerical length of the segment \overline{XY} . Thus again, \overline{XY} is a geometrical object, a line segment, while XY is a number.

Task 3 Consider the regular pentagon⁸ pictured below. If we drew in radius lines from the center to the vertices of the pentagon, how large would the angles be between consecutive radii around the figure?

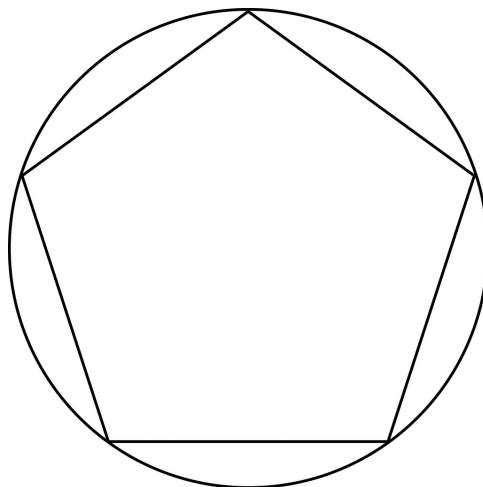

Task 4 If a regular heptagon (7-sided) were inscribed in a circle, and the seven radii drawn in from the center to each of the vertices of the heptagon, how large would the angles be between consecutive radii around the figure? Here, the answer cannot be given exactly in degrees, so round off your answer to the nearest second of arc.

It takes somewhat more than twelve lunar months for the Sun to make its yearly trek around the heavens along the ecliptic circle and return to the same place relative to the background stars. One twelfth of the way around this 360-degree circle should be roughly equal to a month, the time it takes for the Moon to go through a full cycle of its phases. This amounts to $360^\circ \div 12 = 30^\circ$, a nice round number in the sexagesimal system (consisting of exactly one half of a unit of sixty parts). Thus the Sun travels along a 30° arc of the ecliptic circle about once a month, and so, each of these 30° arcs was matched to a corresponding constellation along the zodiacal band.⁹ This was the mechanism whereby the Babylonians used the sky as a calendar. Since their year began at the spring equinox, the Sun would pass through the first of these constellations, Aries the Ram, during the first month of the year, corresponding to the 0° to 30° band along the ecliptic.¹⁰ During the second month, the Sun

⁸A polygon is called *regular* if all its sides and angles are mutually congruent.

⁹The zodiacal constellations, in the order through which the Sun passes through them from the beginning of spring, through the summer, fall and winter months, are: Aries, Taurus, Gemini, Cancer, Leo, Virgo, Libra, Scorpio, Sagittarius, Capricorn, Aquarius and Pisces. The reader will recognize that these are also the astrological signs to which modern-day horoscopes are associated. One's horoscope is cast depending on where the Sun was found in the sky on the day one was born.

¹⁰Today, because the axis of the earth's rotation performs a slow gyroscopic rotation relative to the plane of its orbit around the Sun (a motion called the *precession of the equinoxes* by astronomers), the spring equinox no longer finds the Sun in the constellation Aries, but rather in Pisces. In fact, this slow movement will soon push the Sun at equinox into the next zodiacal constellation, Aquarius. That is, we are inexorably moving into the Age of Aquarius, as announced in the famous 1967 Broadway musical *Hair!*.

would be in Taurus the Bull (30° to 60° along the ecliptic), then Gemini the Twins (60° to 90° along the ecliptic), etc. By the end of the following winter, the Sun would complete its journey through the twelfth zodiacal band, for Pisces the Fish (330° to $360^\circ = 0^\circ$ along the ecliptic), returning to its starting point for the next year's course. (The diagram below sketches how this works, but it is drawn from the modern perspective, showing the Earth orbiting the Sun.)

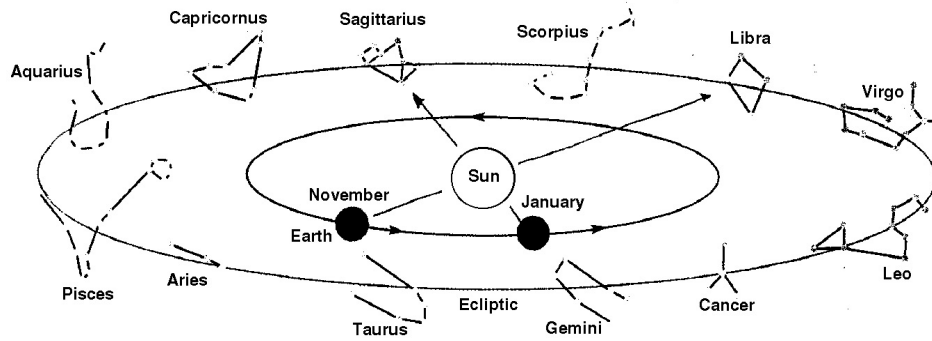

More importantly to our story, the legacy left by Babylonian astronomers was taken up by Greek astronomers centuries later, thence by Islamic, and later European scholars.¹¹ Since the science of timekeeping was the business of astronomers who tracked the motions of the Sun and Moon across the sky, its regulation was their responsibility, and the Babylonian tradition of numerical reckoning in sexagesimal numbers became standard for this purpose. This is why the sexagesimal system we use for angle measure also became the system we still use today for measuring time: hours of 60 minutes each, and minutes of 60 seconds each.¹²

2 Hipparchus and Ptolemy: a Table of Chords

Hipparchus of Rhodes was an astronomer, geographer, and mathematician who lived during the second century BCE. As is the case with most notable figures of the ancient world who were not military, political, or religious leaders, we know very little about his life, save that he was born in Nicaea, the major city of the kingdom of Bithynia (the region around present-day Istanbul, Turkey), that he died in Rhodes (the largest of the Aegean islands), and that he was an accomplished astronomer. He was among the first to set forth a *heliocentric* planetary theory, one that put the Sun at the center of a system of planets which orbit it.¹³ Only one of his writings still survive, and this is a very minor treatise; our interest in him here is due to the fact that he was cited significantly by another much more influential astronomer, Claudius Ptolemy, who lived some 300 years later in the second century CE in Alexandria in Egypt. Ptolemy's reference to the work of Hipparchus helped to preserve for modern readers some of the earlier astronomer's work.

¹¹In subsequent sections of this project, we will investigate brief episodes from this long tradition.

¹²In fact, long after astronomers in ancient Egypt divided the nighttime into 12 hours, and the daytime similarly into 12 hours, Greek astronomers adopted Babylonian sexagesimal methods to similarly subdivide the hour into minutes and seconds. Later scientists, from medieval through modern times, continued these traditions (Richards, 1998). Thus, sexagesimal numeration persists in our modern lives in substantial ways.

¹³Based on mentions of him by other writers, it appears that Aristarchus of Samos was the first to posit that the Sun was the center of the universe; Aristarchus lived about a century before Hipparchus.

Ptolemy was the author of many scientific treatises that survive to the present, the most important of which was the *Almagest*,¹⁴ a compendium of his own astronomical theories. In this work Ptolemy illustrated with geometric demonstrations his *geocentric* model for the movement of the Sun, Moon and planets about the Earth.¹⁵

What characterized the Greek contributions to the development of astronomy was their incorporation of ideas from new advances in the study of geometry. These theories gave them the means to describe more clearly how it is that heavenly objects move the way they do, descriptions based on objectively deductive principles about the nature of geometrical objects.

In our first passage from the *Almagest* (I.2¹⁶), Ptolemy summarized some basic astronomical principles in geometric terms, making it clear that the most important geometry of interest to astronomers was that of the sphere and the circle.

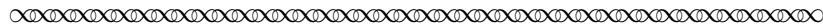

... the heaven is spherical in shape, and moves as a sphere; the earth too is sensibly spherical in shape, when taken as a whole; in position it lies in the middle of the heavens very much like its centre; in size and distance it has the ratio of a point to the sphere of the fixed stars; and it has no motion from place to place.

... the ancients ... saw that the sun, moon and other stars were carried from east to west along circles which were always parallel to each other, that they began to rise up from below the earth itself, as it were, gradually got up high, then kept on going round in similar fashion and getting lower, until, falling to earth, so to speak, they vanished completely, then, after remaining invisible for some time, again rose afresh and set; and [they saw] that the periods of these [motions], and also the places of rising and setting, were, on the whole, fixed and the same...

No other hypothesis but [the sphericity of the heavens] can explain how sundial constructions produce correct results; furthermore, the motion of the heavenly bodies is the most unhampered and free of all motions, and freest motion belongs among plane figures to the circle and among solid shapes to the sphere...

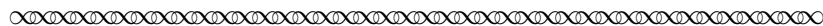

At the beginning of this excerpt, Ptolemy described the vastness of the heavens by stating that “in size and distance [the Earth] has the ratio of a point to the sphere of the fixed stars.” That is,

¹⁴The name *Almagest* was not the title given to the work by its author. Ptolemy gave it a much more prosaic title, *The Mathematical Collection*, but as it was much studied by astronomers in subsequent centuries, it became known more simply as *The Great Collection*. Centuries later, Arabic scholars translated it into their own language with this same title as *Kitāb al-majistī*, and even later, European scholars produced Latin translations, transliterating the title as *Almagest*.

¹⁵It is instructive to consider how it is that Ptolemy’s work survives today while Hipparchus’ does not. This is in no small part due to the spectacular success of the reputation of the *Almagest* among astronomers who came after Ptolemy. In an age before the invention of printing, Ptolemy’s work was copied by hand, again and again, while the works of earlier scholars were eclipsed or superseded by Ptolemy’s and were set aside. Eventually, the older manuscripts were forgotten, decayed and were lost, except for those mentions in other books by those who had read them in ages past. Furthermore, Ptolemy had the good fortune to have his works preserved at the famous Museum Library in Alexandria, the modern-day source of a vast amount of scientific literature of the ancient world.

¹⁶This notation indicates that the passage comes from Section 2 of Book I of the *Almagest*.

wherever one was located on the surface of the Earth, it made sense to consider yourself at the center of the immense celestial sphere. In this way, he also made clear his cosmological view: unlike Hipparchus, who thought that the Sun was at the center of the universe with the Earth and planets circling it, Ptolemy believed not only that the Earth was at the center, but that its location was fixed: “it has no motion from place to place.”¹⁷

At the core of the Greek understanding of the motion of the heavens, then, is knowledge of the geometry of the sphere and its two-dimensional counterpart, the circle, which describes the paths of the heavenly bodies around the celestial sphere. We have explored a little of this circular geometry in the tasks set out earlier in this project, and we will investigate more of this in what follows. The application of this geometry to handling problems in astronomy is the real origin of what would eventually become trigonometry.

Task 5

In Task 2(c), we learned that in a 60° sector of a circle, the segment \overline{AB} spanning this central angle is as long as the radius of the circle. That is, in the diagram below, if $OA = 1$ and $\angle AOB = 60^\circ$, then $AB = 1$. In Task 2(e), we found that, where $\angle AOA' = 30^\circ$, it must follow that $\overline{OA'}$ is perpendicular to \overline{AB} .

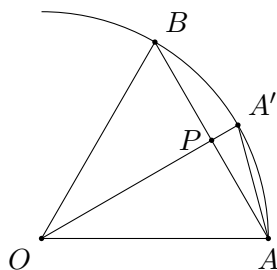

- Use the fact that triangle AOA' is isosceles, to determine the angles in triangle APA' .
- Use the results from Task 2(e) and the Pythagorean Theorem to find the lengths of the sides of triangle APA' , and in particular, the length of $\overline{AA'}$.
- The segment $\overline{AA'}$ is one side of a regular polygon which can be inscribed in the circle with radii \overline{OA} and $\overline{OA'}$. How many sides does this polygon have?

Greek geometers had techniques to determine the exact lengths of the sides of certain regular polygons, as in the task above, but not others: the length of the regular heptagon (see Task 4) could only be approximated. Given a circle with center point O and any two radii, \overline{OA} and $\overline{OA'}$, these radii will bound the central angle $\angle AOA'$, corresponding to the arc from A to A' . The line segment $\overline{AA'}$ is called the *chord* corresponding to $\angle AOA'$.

¹⁷Indeed, except for the rare occurrence of an earthquake, humans perceive no movement of the Earth; the sky actually does appear to move around the observer! Modern science only succeeded in convincing the general public of the view that the Earth moves around the Sun after centuries of argument and rhetorical harangues, largely through the work of Copernicus and Galileo in the sixteenth and seventeenth centuries. Later, in the twentieth century, astronomers realized that even this view was incomplete: the galaxies that make up the universe are generally receding from each other over time. That is, no matter where you are in the universe, distances to the galaxies around you are expanding with time. So in some sense, the universe has no center at all.

It was recognized early on that knowledge of the lengths of chords that spanned angles at the center of a circle would be extremely useful for solving astronomical problems. Thus, it is not surprising to learn that Hipparchus was reported to have prepared a table of central angles and their corresponding chords for use by astronomers (and astrologers). We have independent reports from Vettius Valens (120 - ca. 175 CE), a contemporary of Ptolemy, and the author of a respected astrological work, and also from Theon of Alexandria (ca. 335 - 405 CE), in his *Commentary on the Almagest*, that Hipparchus had indeed prepared such a table. Unfortunately, no copy of this work of Hipparchus survives today. However, a number of scholars in recent years have proposed a likely reconstruction of his table, which we present below.¹⁸

Figure 1: **Hipparchus' Table of Chords (Reconstruction)**

Arcs	Chords	Arcs	Chords
[7, 30]	[7, 30]	[97, 30]	[86, 9]
[15, 0]	[14, 57]	[105, 0]	[90, 55]
[22, 30]	[22, 21]	[112, 30]	[95, 17]
[30, 0]	[29, 40]	[120, 0]	[99, 14]
[37, 30]	[36, 50]	[127, 30]	[102, 46]
[45, 0]	[43, 51]	[135, 0]	[105, 52]
[52, 30]	[50, 41]	[142, 30]	[108, 31]
[60, 0]	[57, 18]	[150, 0]	[110, 41]
[67, 30]	[63, 40]	[157, 30]	[112, 23]
[75, 0]	[69, 46]	[165, 0]	[113, 37]
[82, 30]	[75, 33]	[172, 30]	[114, 21]
[90, 0]	[81, 2]	[180, 0]	[114, 35]

How are we to make sense of the numbers in this table? First, because it is supposed to be the work of a Greek astronomer working within the tradition of Babylonian science, we must interpret the numbers in the table as sexagesimal. Next, it is clear that the values in the Arcs column should be measuring arcs along a circle, or equivalently, angles at the center of a circle, since they end at the telling value [180, 0],¹⁹ which appears to be indicating an arc of 180°. If this is the case, then the first entry [7, 30] in the Arcs column should represent an arc of $7\frac{1}{2}^\circ$, the second entry would represent 15°, the third $22\frac{1}{2}^\circ$, and so on, all entries being successive multiples of the first one.

However, as we have learned, if these Arcs are being measured in units of degrees, then we should

¹⁸For a deeper discussion of how this table was reconstructed, and “convincing, but circumstantial” rationale for it, see (Van Brummelen, 2009, 41-46). Since this table is not taken from a historical documented source, we do not present it here in the sans-serif font we reserve for such texts.

¹⁹Because there is no actual document authored by Hipparchus to consult here, there is no way of knowing if, much less how, the entries in the Arcs column ending in 0 actually displayed this 0 as a zero symbol. For instance, the entry [180, 0] might have been entered as [180,]!

expect all the commas in these entries to properly be semicolons: $[7, 30]$ is supposed to represent the number $7 \cdot 60 + 30 = 450$, not $7\frac{1}{2}$. That number would be written as $[7; 30]$. But perhaps they were not meant to be interpreted in units of degrees, but in units of arcminutes, that is, in units of sixtieths of a degree. Under this scheme, $[7, 30]$ would be interpreted as $7 \cdot 60 + 30 = 450$ arcminutes, which is the same as $7\frac{1}{2}^\circ$. In the end, then, it doesn't much matter which interpretation you give: $[7, 30]$ arcminutes measures the same arc which measures $[7; 30]$ degrees.

Also, notice that the later entries in both columns of the table are not properly rendered in true sexagesimal form. For instance, the final entry of $[180, 0]$ arcminutes in the Arcs column ought to be written in sexagesimal as $[3, 0, 0]$: the number 180 is not a proper sexagesimal digit, as it is greater than or equal to 60. Ptolemy was guilty of this same "laziness" in his published table of chords in the *Almagest* I.11 (Toomer, 1998). There, Arcs were consistently measured in units of degrees, and fractions of a degree used the sexagesimal system of treating minutes as sixtieths of a degree and seconds as sixtieths of a minute. In measuring arcs larger than 60 degrees, however, Ptolemy failed to maintain the system of digit grouping that would necessitate adding an extra sexagesimal digit to the left of the one used for degrees. Greeks of his time did not use the same system that Babylonian scribes had used for writing *cuneiform* on wet clay tablets;²⁰ Greeks wrote with ink on papyrus or parchment,²¹ and in the Greek tradition, numbers were recorded using a base-10 system (Pedersen, 2011, pp. 49-52). Still, Greeks continued to make use of this "hybrid" sexagesimal number system of degrees/minutes/seconds whenever they measured arcs or angles to do astronomical mathematics.

Task 6

- (a) In Tasks 2(a) and 5(c), you measured the central angles that corresponded to chords which were sides of certain regular polygons inscribed in a circle. Do these angles appear as listed Arcs in Hipparchus' Table?
- (b) The inscribed regular polygon in Task 5(c) was obtained by halving the arcs between the vertices corresponding to the inscribed regular polygon in Task 2(a). If this halving process is repeated once more, how many sides will the resulting inscribed regular polygon have? And does the Arc between the vertices of this polygon appear in Hipparchus' Table? What is its measure?
- (c) How many times can the step in (b) above be repeated so that the resulting arc still appears in Hipparchus' Table? How many sides do the resulting polygons have, and what is the measure of the arcs between their consecutive vertices?

The column labeled Chords in Hipparchus' Table ought to carry the values of the lengths of the corresponding chords. We will adopt a simple notation for this, referring to the Chord for a given Arc with the notation Crd: for instance, we see from the table that $\text{Crd}[37, 30] = [36, 50]$. Notice that the numbers in this second column are roughly equal to those in the first column near the beginning

²⁰ *Cuneiform* is the term for writing on wet clay surfaces using a *cuneus*, a wedge-shaped reed stylus ('*cuneus*' is Latin for 'wedge'). This form of writing technology emerged in Sumerian Mesopotamia sometime after 3500 BCE.

²¹ *Papyrus* is a paper-like substance fashioned from the fibrous innards of the papyrus plant, a grassy reed that thrived in the marshlands around the Eastern Mediterranean. *Parchment* is another kind of writing surface manufactured from the dried skins of domesticated animals like sheep, goats, or calves; the word derives from the name of the city of Pergamon, a town that once stood on the Aegean coast of modern-day Turkey, and was a center of production of high quality parchment in the ancient world.

of the table, but that they appear to grow less quickly as the size of the arcs increases. We know that sexagesimal numbers are used to measure angles and arcs, but how are they also being used to measure lengths of line segments? Our first clue is to consider the first table entry: it reports that the Chord corresponding to an Arc of $7\frac{1}{2}$ degrees is also $[7, 30] = 7\frac{1}{2}$, i.e., $\text{Crd}[7, 30] = [7, 30]$. But if the length of the arc of a circle is a distance, we can imagine straightening this length to obtain a line segment of the same measure. That is, we could measure the chord in the same units as the arc. The diagram below shows that the arc and the chord are indeed roughly equal, as they are hard to distinguish when the angle is small, just as Hipparchus' Table confirms.

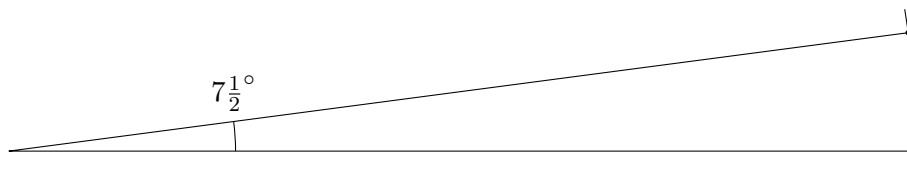

This gives evidence that the Chord entries were interpreted as lengths in the same units of minutes of arc as were used to measure the lengths of Arcs along the circle.

Task 7

- Recall the formula you learned in school that relates the circumference C of a circle and its radius r . (If you've forgotten it, look it up.) Given that the circle contains 360° , how many minutes of arc measure the entire circumference of the circle? According to the formula, how long is the radius of the circle in arcminutes?
- From Task 2(c), we conclude that $\text{Crd}[60, 0]$ should be equal to the radius of the underlying circle. Show how Hipparchus' Table verifies this.
- What then is the length of the diameter of the circle? How does this relate to the tabulated Chord length for Arc 180° ?

Task 8

In Hipparchus' Table, Arcs step up in units of $7\frac{1}{2}^\circ$. Arcs greater than 180° would not need to be considered, since their chord values would simply repeat ones already found in the table. Verify this by drawing a picture displaying a circle with central angle whose corresponding arc on the circle has measure $187\frac{1}{2}^\circ$, the next entry that would have appeared in the table if it were to continue past 180° . What entry in the table already gives the corresponding chord value? According to the table, what is the measure of the Chord for Arc $337\frac{1}{2}^\circ$?

Task 9

Use the Pythagorean Theorem together with the result of Task 7(b) to verify the table value for $\text{Crd}[90, 0]$.

Task 10

Translate the entire Table of Chords from sexagesimal into decimal numbers, using both degrees and arcminutes for the Arcs column but only arcminutes for the Chords column. For instance, the first pair of entries would give an Arc measure of $7^\circ 30'$ and a Chord measure in arcminutes of $7 \cdot 60 + 30 = 450'$. Similarly, the second pair of table entries illustrate that $\text{Crd } 15^\circ 0' = 14 \cdot 60 + 57 = 897'$.

3 Ptolemy: Finding the height of the Sun at your feet

As an example of how the geometry of the circle played such an important role for Greek astronomers, consider the problem of designing an effective sundial. Ptolemy addressed this problem in *Almagest* II.5 (Toomer, 1998), an excerpt of which we will read below. In this passage, Ptolemy wanted to predict the lengths of noonday shadows on certain special days of the year, shadows cast by a *gnomon*, a vertical stick placed in the ground.

He knew that for any observer like himself who lives north of the terrestrial equator, the Sun rides highest in the sky at noon on the day of the summer solstice (around June 21 in our calendar) and lowest on the day of the winter solstice²² (around December 21). In addition, halfway between the solstices are the equinoxes, one on the first day of spring (around March 20) and one on the first day of fall (around September 22). On these days, the amount of daylight is the same as the amount of night²³ – twelve equal hours each, and the Sun rises and sets at the same points on the horizon on both days.

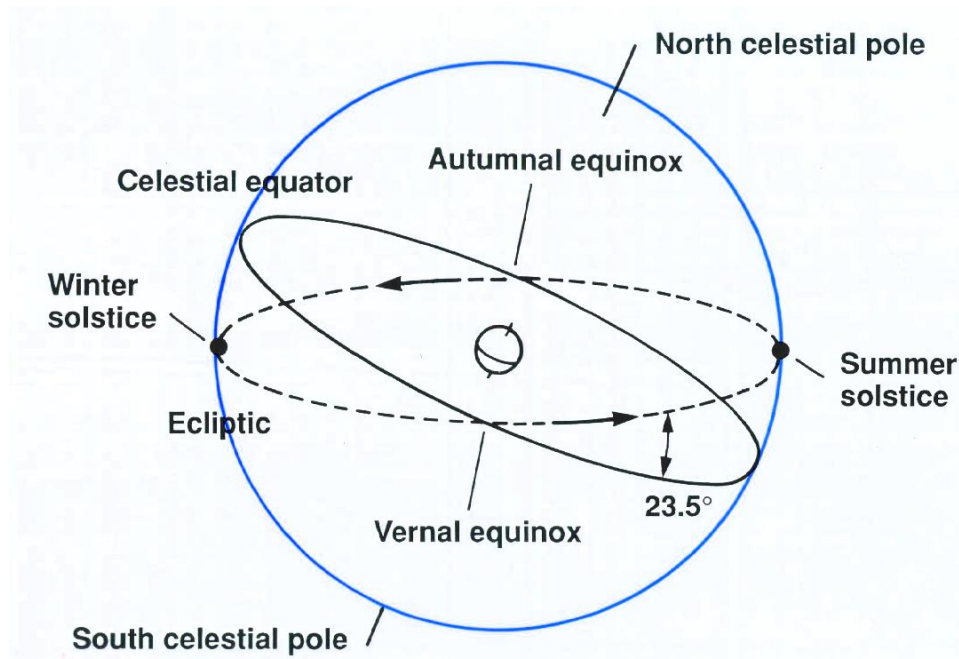

The ecliptic circle, the path that the Sun travels in its annual circuit across the background stars, is different from the celestial equator, the equator of the sphere that holds the stars in their place in the sky above us and that appears to rotate about us once a day about an imaginary axis through the Earth's center that points toward Polaris, the North Star. (See the diagram above.²⁴) The ecliptic circle is tilted with respect to the celestial equator, by an amount precisely equal to the tilt of Earth's rotational axis from the axis of the orbit of Earth around the Sun (which is vertical in

²²The word *solstice* comes from fusion of the Latin words for 'sun', *sol*, and 'to stand still', *sistere*; the solstices refer to those days when the sun stops moving northward or southward in the sky, and appears to turn around to begin moving in the opposite direction. Modern science tells us that the sun is high in the sky, allowing it to remain in the sky in the northern hemisphere for more than 12 hours a day, when the tilt of the earth's axis in the north is directed toward the star; the sun rides low in the sky and remains up less than 12 hours a day when the earth's axis is tilted away half a year later.

²³The word *equinox* is likewise the merging of Latin words for 'equal', *aequus*, and night, *nox*.

²⁴<http://faculty.virginia.edu/skrutskie/images/ecliptic0.jpg>

the diagram). In *Almagest* I.14, Ptolemy determined this angle of tilt, called the earth’s *obliquity*, to be $[23; 51, 20]^\circ$.²⁵ As we have observed already, the ecliptic circle intersects the celestial equator in two diametrically opposite points, namely, the positions of the Sun on the two days of equinox (at the start of spring and the start of fall). The Sun is located at the summer solstice at that point on the ecliptic which is highest above the celestial equator, and at the winter solstice at that point on the ecliptic which is lowest below the equator. Consequently, shadows cast by the Sun at noon are shortest on the summer solstice north of the terrestrial equator, longest on the winter solstice, and take the same middle value on both days of equinox.

Now the particular height of the Sun at noon on any given day of the year also depends on where on the earth the observer stands. If the observer lives further north, then Polaris, which is very near the north pole of the celestial sphere (what Ptolemy calls “the sphere of the Sun”), lies higher in the sky than for someone who lives further south, closer to the earth’s equator. After all, the celestial equator sits exactly above the terrestrial equator, just as Polaris is situated directly above the terrestrial North Pole. Someone at the earth’s North Pole will see Polaris directly overhead, and the observer’s horizon will coincide with the celestial equator; someone living at the equator will find the celestial north pole on the horizon and the celestial equator will cross that person’s *zenith*, the point in the sky directly overhead. More generally, for any observer in the earth’s northern hemisphere, the terrestrial latitude of the observer, that is, the angle of arc along the circle that passes through the observer’s position and the North Pole, measured between the equator and the observer’s location, is the same as the angle of elevation that Polaris (the celestial north pole) makes with the observer’s horizon. In the passage we read below, Ptolemy considers an observer on the 36th parallel (where the latitude is 36°), corresponding, for example, to the position of the island of Rhodes in the Aegean Sea.

In the first part of this excerpt from the *Almagest*, Ptolemy constructed his geometric model of the *gnomon*,²⁶ and arranged a diagram to represent it.²⁷

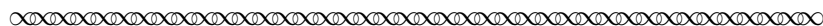

The required ratios of shadow to gnomon can be found quite simply once one is given the arc between the solstices and the arc between the horizon and the pole; this can be shown as follows.

Let the meridian circle be $ABGD$,²⁸ on centre E .²⁹ Let A be taken as the zenith, and draw diameter AEG . At right angles to this, in the plane of the meridian, draw $GKZN$; clearly, this will be parallel to the intersection of horizon and meridian. Now, since the whole earth has, to the senses, the ratio of a point and centre to the sphere of the sun, so that the centre E can be considered as the tip of the gnomon, let us imagine GE to be the gnomon, and

²⁵Ptolemy’s value is larger than the value indicated in the figure above. In fact, this quantity fluctuates over time, since the Earth spins like a top, in such a way that this angle of obliquity oscillates between about 22° and 24.5° over a period of over 40,000 years!

²⁶*Gnomon* is another Greek word that might best be translated ‘indicator’ (literally, “the one who knows”); it refers to an object whose shadow is used to tell the time of day.

²⁷I have added dotted lines and labels to Ptolemy’s diagram for the celestial North Pole and Horizon to help the reader interpret these elements.

²⁸The *meridian* of an observer is that imaginary circle on the celestial sphere which passes through the observer’s zenith and the points on the horizon which point due north and due south.

²⁹Note that the points in Ptolemy’s diagram are labeled using the Greek alphabet: Alpha, Beta, Gamma, Delta, Epsilon, Zeta, Eta, Theta (Θ), Iota, Kappa, Lambda, Mu, Nu, etc.

line GKZN to be the line on which the tip of the shadow falls at noon. Draw through E the equinoctial noon ray and the [two] solstitial noon rays: let BEDZ represent the equinoctial ray, HEΘK the summer solstitial ray, and LEMN the winter solstitial ray. Thus GK will be the shadow at the summer solstice, GZ the equinoctial shadow, and GN the shadow at the winter solstice.

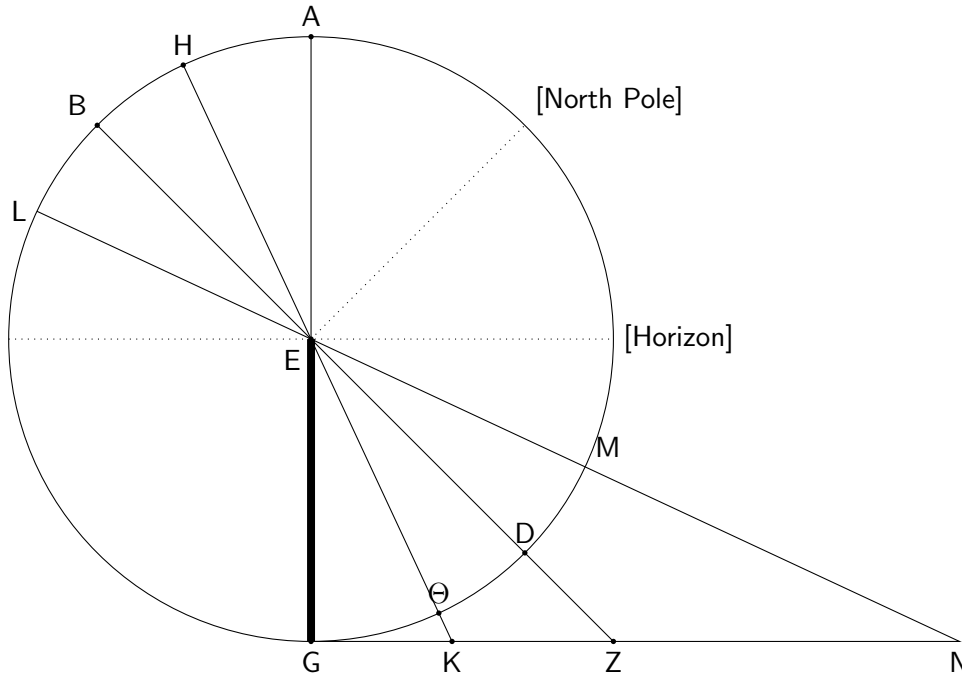

Then, since arc GD, which is equal to the elevation of the north pole from the horizon, is 36° ... at the latitude in question, and both arc ΘD and arc DM are $[23; 51, 20]^\circ$, by subtraction arc $G\Theta = [12; 8, 40]^\circ$, and by addition arc $GM = [59; 51, 20]^\circ$.

Therefore the corresponding angles

$$\begin{aligned} \angle KEG &= [12; 8, 40]^\circ, \\ \angle ZEG &= 36^\circ, \\ \angle NEG &= [59; 51, 20]^\circ \end{aligned}$$

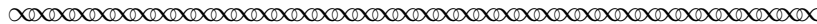

Task 11

What does Ptolemy mean in the first sentence by “the arc between the solstices” and “the arc between the horizon and the pole”? How are these related to the obliquity of the earth and the latitude of the observer at Rhodes?

Task 12

Verify Ptolemy’s calculations of the sizes of arcs $G\Theta$ and GM .

Here is the rest of this excerpt from the *Almagest*:

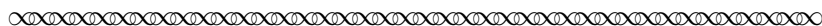

Therefore in the circles about right-angled triangles KEG, ZEG, NEG,

$$\begin{array}{ll} \text{arc GK} = [24; 17, 20]^\circ & \text{and arc GE} = [155; 42, 40]^\circ \text{ (supplement),} \\ \text{arc GZ} = 72^\circ & \text{and arc GE} = 108^\circ, \text{ similarly [as supplement],} \\ \text{arc GN} = [119; 42, 40]^\circ & \text{and arc GE} = [60; 17, 20]^\circ \text{ (again as supplement).} \end{array}$$

Therefore

$$\begin{array}{ll} \text{where Crd arc GK} = [25; 14, 43]^p, & \text{Crd arc GE} = [117; 18, 51]^p, \\ \text{and where Crd arc GZ} = [70; 32, 4]^p, & \text{Crd arc GE} = [97; 4, 56]^p, \\ \text{and where Crd arc GN} = [103; 46, 16]^p, & \text{Crd arc GE} = [60; 15, 42]^p. \end{array}$$

Therefore, where the gnomon GE has 60^p , in the same units

$$\begin{array}{l} \text{the summer [solstitial] shadow, GK} \approx [12; 55]^p, \\ \text{the equinoctial shadow, GZ} \approx [43; 36]^p, \\ \text{the winter [solstitial] shadow, GN} \approx [103; 20]^p. \end{array}$$

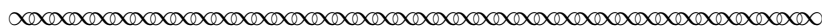

Before we attempt to make sense of this last bit of text, let us first highlight a fundamental fact from the geometry of circles which will come in handy for us: *If an angle $\angle PQR$ is inscribed in a circle with center O (that is, all three points P, Q, R lie on the circle), then the measure of $\angle PQR$ equals half the measure of the arc PR (or, equivalently, of the central angle $\angle POR$).* This fact is recorded in Euclid's *Elements* as Proposition III.20, in the following form: In a circle, the angle at the center is double the angle at the circumference when the angles have the same circumference as base. Because of its appearance in the *Elements*, Ptolemy (and his serious readers) would have been well aware of it.

Task 13

In this Task, we investigate why Euclid's proposition, *Elements* III.20, holds.

- (a) Draw a circle with center O and identify three points P, Q, R on the circumference. There are three cases for how these points can be arranged; our first case corresponds to where two of the points, say Q and R , are diametrically opposite one another (so that O lies on one side of the angle $\angle PQR$). Complete such a drawing, then explain why the central angle $\angle POR$ must be twice as large as the inscribed angle $\angle PQR$. (Hint: what kind of triangle is $\triangle OPQ$, and what then must be the relationships between its interior and exterior angles?)
- (b) Now arrange the points P, Q, R around the circle so that O lies within $\angle PQR$. To show why the same result holds here, let Q' be the point diametrically opposite Q on the circle, so that $\angle PQR$ can be divided into two angles $\angle PQQ'$ and $\angle Q'QR$. Apply the case from part (a) above to each of these smaller angles to complete the justification in this case.

- (c) Finally, arrange the points P, Q, R around the circle so that O lies outside $\angle PQR$. Once again, let Q' be the point diametrically opposite Q on the circle. This time, $\angle PQR$ is the difference between angles $\angle PQQ'$ and $\angle Q'QR$. Apply the case from part (a) again to each of the last two angles, and complete the full justification.

Task 14

In the opening sentence of the last excerpt, Ptolemy proposed to take the three right-angled triangles KEG , ZEG , and NEG , out of the diagram and in each case, inscribe them within a circle.

- (a) In general, if PQR is a right-angled triangle with right angle at Q , use the result just quoted about the measure of inscribed angles to explain why it must be that the circle in which the triangle is inscribed must have center O at the midpoint of the hypotenuse \overline{PR} .
- (b) Now suppose that triangle KEG is inscribed in a circle; explain why arc $GK = [24; 17, 20]^\circ$ and arc $GE = [155; 42, 40]^\circ$ as Ptolemy indicated. Similarly verify the corresponding measures of the arcs that Ptolemy reported for the circles that circumscribe the triangles ZEG and NEG .

In the middle sentence of the last excerpt, Ptolemy consulted his own table of chords, an updated and much more extensive table than the one produced by Hipparchus 300 years earlier. As had Hipparchus (according to the reconstruction we proposed), Ptolemy tabulated the measures of arcs in degrees and the corresponding measures of the chords that spanned those arcs within a certain reference circle. But Ptolemy's table was far more extensive: he recorded chords for every arc from 0° to 180° in steps of $\frac{1}{2}^\circ$. Moreover, while Hipparchus measured his chords in units of arcminutes, Ptolemy did not; he chose the reference circle to have a radius of unit length, subdivided sexagesimally into 60 parts. He then measured the chords in the same unit of parts of the radius' length. In the text, when he wrote "where Crd arc $GK = [25; 14, 43]^p$," he was saying that the chord spanning the arc GK measures $[25; 14, 43]$ parts in units where the radius of the circle measures 60 parts.

Task 15

If we inscribe the right triangle KEG in a circle of radius one unit = 60 parts, this will match the setup for Ptolemy's table of chords. Assuming that Ptolemy has correctly determined that Crd arc $GK = [25; 14, 43]^p$, use the Pythagorean Theorem to verify that Crd arc $GE = [117; 18, 51]^p$. Similarly, verify the values of Crd arc GE from the text that correspond to inscribing each of the other two right triangles, ZEG and NEG , in a circle of radius one unit = 60 parts.

Task 16

Finally, in the last sentence of the excerpt, Ptolemy resized the dimensions of the three triangles: whereas he had originally used units in which the radius of the circumscribing circle is 60 parts (from his table of chords), he now wanted to recalibrate so that the vertical side of the triangle, the gnomon \overline{GE} , has 60 parts. This simply required the use of a proportion to make the final calculations. For instance, \overline{GK} and \overline{GE} , the sides of right triangle KEG , have the same ratio to each other when inscribed in a circle of radius 60 parts (as when we use Ptolemy's table of

chords) as they would if the measuring scale were reset so that the gnomon \overline{GE} now equaled 60 parts, as in the original diagram:

$$\frac{[25; 14, 43]^p}{[117; 18, 51]^p} = \frac{GK}{GE} = \frac{?}{60^p}.$$

Solving the proportion for the unknown gives the length of the summer solstitial shadow that \overline{GK} represents. Verify that we get the same value for the summer solstitial shadow that Ptolemy obtained. Then do the similar calculations to verify Ptolemy’s calculations for the lengths of the equinoctial shadow \overline{GZ} and the winter solstitial shadow \overline{GN} .

4 Varāhamihira: Sines in Poetry

Varāhamihira (505-587 CE) was a prolific astronomer/astrologer of the sixth century who lived in central India near the end of the two-century-long rule of the Gupta Empire. The reign of the Guptas was a time of general peace and prosperity throughout the northern part of the Indian subcontinent and is associated with a golden age of art, architecture, Sanskrit literature, mathematics, astronomy, and medicine (Katz, 1998). It was around this time that decimal positional numeration with a system of ten digits, including a symbol for zero, was first used to perform arithmetic. This system evolved over the centuries and was picked up by Muslim scholars to the west of India to become the Indo-Arabic numeration system in use now throughout the world.

Some scholars think that Varāhamihira was a court astronomer and astrologer to the Maharajah of Daśapura (modern day Mandasor, India). Whether or not this is true, he was an expert both in Greek astronomy and in astrology in the Greek, Roman, and Egyptian traditions; he was the author of a number of works in mathematical astronomy. We will consider the first eight verses from part IV of his *Pañcasiddhāntikā* (Neugebauer and Pingree, 1970/1972), dating from around 575 CE. *Pañca* is Sanskrit for “five”,³⁰ and *siddhānta* refers to a “dogma” or canonical text, so it makes sense to translate the title of this work as *The Five Canons*. In it, Varāhamihira comments on five earlier Hindu works in mathematical astronomy and astrology (Plofker, 2008).

Sanskrit was the language of Hindu priest-scholars. This scholarship was founded on the long tradition of the Vedas, epic poems about mythology, theology, and Hindu practice whose creation dates from around 1500 BCE (Katz et al., 2007). These texts were intended to be memorized and recited by devotees, and were only written down for the first time in about 500 BCE. As a member of this tradition, Varāhamihira also composed in Sanskrit verse.

One of our primary interests in this passage is to notice a key development in the history of trigonometry, namely, the shift in interest from tabulation of the chord of an arc or angle to that of its *sine* (and *cosine*) as the focus of attention. In many applications of chord tables to problems in computational astronomy, the problems called for finding the measures of the sides of some right triangle, given one of its angles – call it θ – and the length of its hypotenuse – which for simplicity we will take to be the same radius used to prepare a table of chords.

The obvious way to use the table to solve this sort of problem is to look up the angle twice as large as the given angle (2θ) to find its chord, Crd 2θ (in Sanskrit, the word for “chord” was *jyā*). Half this

³⁰Also the root of the English word ‘punch,’ a blow from a five-fingered hand!

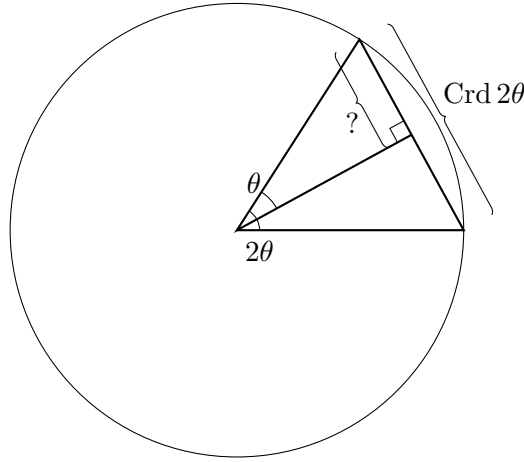

magnitude (in Sanskrit, the *ĵyā-ardha*) will give the side of the right triangle opposite the angle θ . Having to use this process repeatedly probably influenced Hindu astronomers to stop tabulating the chord length and start tabulating the *ĵyā-ardha* instead. After a time, the term for half-chord was shortened to simply *ĵyā*; centuries later, Arabic scholars transliterated this Sanskrit word into Arabic as *jiba*. Then in the twelfth century, a European Latinist mistranslated this Arabic word, thinking that it was the word *jaib* instead (in written Arabic, vowels appear only as diacritical marks), which means “bosom” or “fold”, so he rendered it as the Latin word for “fold”, namely *sinus* (the same word we use to describe the folded layers of the nasal cavity). This became the English word *sine*!

In the passage below (taken from (Neugebauer and Pingree, 1970/1972)), Varāhamihira produces the beginning of a Table of Sines in Sanskrit verse. He begins by orienting us to the geometric content of the *Pañcasiddhāntikā*, in which the basic facts of circle geometry are being laid out. It is important to note that for Varāhamihira, the word *Sine* (specifically written here with a capital S) refers to the side of the right triangle opposite the given angle in a triangle whose radius R has been given; in contrast, we use the word *sine* (with a lowercase s) to mean the length of the side of the right triangle opposite the given angle in a triangle whose radius has length 1. This is a distinction which may seem trivial, but is of real importance: for the ancients, the Sine was a geometrical line segment whose length was to be determined; for us moderns, a sine is a number which measures a certain distance. In particular, the Sine of an arc differs depending on the radius of the circle in which it lies, while the arc has only one sine.

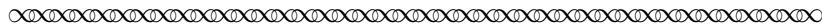

¹The square-root from the tenth part of the square [of a circle] whose circumference is 360 [degrees] is the diameter.

In this [circle], by one establishing four parts [quadrants], the Sine of an eighth part of a zodiacal sign [is to be determined].

²The square of the radius is called the *dhruva*.

A fourth part of this is [the square of the Sine] of Aries [i.e., of 30°].

The *dhruva*-square is diminished by [the square of the Sine] of Aries; the square-root is the Sine for two zodiacal signs [i.e., of 60°].

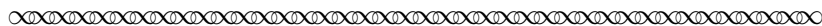

The opening sentence of verse 1 presents a geometric identity: where the “[circle] whose circumference is 360 [degrees]” refers to the full circumference C of the circle, and D stands for its diameter, Varāhamihira is stating, in verse, that

$$\sqrt{\frac{C^2}{10}} = D.$$

Task 17 Use the standard formula you learned in school for the circumference of a circle, and substitute it for C in Varāhamihira’s “formula” above. This will allow you to eliminate D from the formula as well (realizing that the radius of a circle is half its diameter). Solve the resulting equation for the fundamental constant π . This “formula” produces a reasonable approximation for π that was known to Hindu geometers. How many decimal places of accuracy does this approximation give?

Task 18 Recall from our discussion of Babylonian astronomy that the twelve signs of the zodiac partitioned the ecliptic circle into 12 equal arcs of 30° each. From this fact, determine how much “an eighth part of a zodiacal sign” is. This will be the first arc whose Sine is tabulated in Varāhamihira’s table.

The traditional layout of the signs of the zodiac lists the constellations that line up from east to west following the path of the Sun across the background stars during the course of a year along the ecliptic circle, starting in the constellation Aries (the Ram). During the first millennium BCE, the position of the Sun at the spring equinox was in the constellation Aries; this was the point along the ecliptic set as the 0° mark. Following the yearly path of the Sun from east to west, 30° later it passes into the constellation Taurus (the Bull); at the 60° mark, it comes into Gemini (the Twins), then Cancer (the Crab) at 90° , and on through the other twelve constellations, until it finally moves into Pisces (the Fish), at 330° around the ecliptic. This explains why, in the text, when Varāhamihira refers to Aries, he is actually talking about an arc of 30° , and later, when he refers to Taurus, he means an arc of 60° . The constellation names were stand-ins for the arc measures they represented along the ecliptic.

Task 19 Explain what Varāhamihira means in the first line of verse 2 when he says that “a fourth part of [the *dhruva*] is [the square of the Sine] of Aries.” What does this say about the value of the Sine of 30° ? Compare this to the result you discovered in Task 2(e). Use this same result to justify the claim made in the second line of verse 2; what does it say the Sine of 60° is equal to?

The next three verses of the text present rules for determining other Sine values besides those already considered.

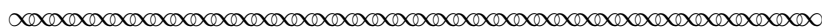

³When the remaining [Sines] are desired, the radius is diminished by the Sine of the remainder of the subtraction of twice the arc from a quadrant; the square of half of that [remainder] is to be added to the square of half [the Sine] of double [the arc].

⁴The square-root of that is the desired Sine.
The *dhruva* diminished by that [square is the square] of the remainder [of the] sum. Half of the *dhruva*-square is called *adhyardha*, [the square of the Sine of] one and a half [signs, or 45°].
Here another rule is described.

⁵The Sine of the arc of three [signs] is diminished by Sine of three signs diminished by twice the given degrees; [the remainder] multiplied by sixty is the square [of the Sine of the given arc].
The *dhruva* diminished by that square is the square of the remainder [i.e., of the Cosine].

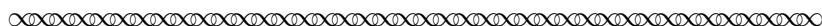

In verses 3-4, Varāhamihira states a rule equivalent to the following formula, in which we recognize that by “quadrant”, he means an arc of 90° :

$$\sqrt{\left(\frac{R - \text{Sin}(90^\circ - 2\theta)}{2}\right)^2 + \left(\frac{\text{Sin } 2\theta}{2}\right)^2} = \text{Sin } \theta.$$

The reader is urged to confirm that the text is faithfully represented in this rather complicated-looking formula. We will not attempt to justify the result in detail, but we do wish to note that this result is one way to propose what will later be called a *half angle formula*, since it allows the computation of the Sine of a given angle, $\text{Sin } \theta$, given knowledge of the Sine of its double, $\text{Sin } 2\theta$.

In particular, the expression $\text{Sin}(90^\circ - 2\theta)$ which appears in the first term under the radical in the above formula, is the Sine of the *complementary arc* to 2θ (arcs being complementary when they sum to a right angle); this Sine of the complement can be found from the Sine of the given angle easily using the Pythagorean Theorem. The Sine of the complementary arc frequently appears in the same calculations as the Sine of the original angle (as both appear as sides in the same right triangle), and the term *Sine-complement* was often used to refer to it. Later, it became known as the *Cosine*.

Task 20

Varāhamihira’s next assertion in verse 4 is that “The *dhruva* diminished by that [square is the square] of the remainder [of the] sum.” Explain why this is yet another version of the Pythagorean Theorem, which in symbolic form, can be expressed as

$$R^2 - (\text{Sin } \theta)^2 = (\text{Cos } \theta)^2.$$

In the case where the radius of the circle has unit length ($R = 1$), the *cosine*, $\cos \phi$, of the angle ϕ is the sine of the complementary angle to ϕ , that is, the other acute angle in a right triangle of hypotenuse with unit length. By definition then,

$$\cos \phi = \sin(90^\circ - \phi).$$

Moreover, the rule from Task 20 then takes the very simple form

$$\sin^2 \theta + \cos^2 \theta = 1.$$

This algebraic identity is often called the *Trigonometric Pythagorean Theorem*.

Task 21 Continue the thread of Task 20 by considering what happens when we apply the result quoted there to the arc equal to “one and a half” zodiacal signs. First, explain why the Sine and Cosine of this angle/arc are the same value, then apply the rule to show that

$$\text{Sin } 45^\circ = \sqrt{\frac{R^2}{2}}.$$

Finally, in verses 6-8, Varāhamihira begins the recitation of the entries of his table of Sine values. He fixes the radius of his circle at $R = 120$, or two units of sixty minutes each, as will become clear.

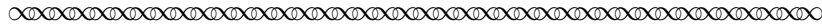

⁶The Sines in Aries are 7, 15, 20 plus 3, plus 11, and plus 18, 45, 50 plus 3, and 60 minutes;

⁷in Aries 50 plus 1, 5 times 8, 5 squared, 4, 30 plus 4, 56, 5, and 0 [seconds].

⁸In Taurus [they are] 6, 13, 19, 3 times 8, and 30 – plus 0, plus 5, plus 9, and plus 13 minutes; in Taurus 40, 3, 7, 50 plus 1, 13, 12, and 60 minus 14 and minus 5 seconds.

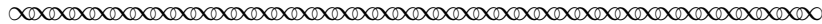

Recall from verse 1 (and Task 18) that Varāhamihira wants to build a table of Sine values for arcs which are multiples of $3^\circ 45'$ of arc. So when he begins by reciting “the Sines in Aries,” he means the Sines of the arcs which are the first few multiples of this smallest reference angle.

Task 22 By the end of this task, you will have extracted Varāhamihira’s full Table of Sines from the above text.

- (a) List the multiples of $3^\circ 45'$ up to 30° and enter them into the first column of a table.

- (b) The second column should list the Sines of the eight corresponding Arcs. In verse 6, Varāhamihira first lists only the parts, in units of minutes, for these values; in verse 7, he lists their smaller parts, in units of seconds. Thus, the first entry gives the Sine of $3^\circ 45'$ as 7 minutes, $50 + 1 = 51$ seconds (or $7'51''$), and the second entry gives $\text{Sin } 7^\circ 30' = 15'40''$. Readers will notice that some of these numbers are identified with rather unusual language: in verse 6, “20 plus 3, plus 11” identifies the two values 23 and 31; and in verse 7, “5 times 8, 5 squared” refer to the two values 40 and 25. Varāhamihira uses this odd language so as to fit the poetic meter of the Sanskrit text, a sense that is entirely lost in our English translation! Now, with this in mind, fill in the rest of this first part of your table with the Sine values reported in verses 6-7.
- (c) In verse 8, Varāhamihira moves on to the next eight entries, filling out the Arcs corresponding to the sign of Taurus. Enter all these Arc and Sine values into your table. All the Sine values are to be added to the 60 minutes which is the Sine of 30° . Thus, $\text{Sin } 33^\circ 45' = 66'40''$. (Warning: the last four entries are spelled out in the verse as adding values to $30'$, using a phrase of the form “plus x ”.)
- (d) Check that the values in Varāhamihira’s table are correct as follows: his Sine values correspond to line segments drawn relative to a circle of radius $R = 2$ units = $120'$. Modern sine values (lowercase s) correspond to choosing a radius of $R = 1$ unit. So add a third column to your table. Place here the (lowercase s) sines of these same Arcs: to determine these, convert the sexagesimal Sine values in minutes/seconds which appear in the second column into sine values (in minutes/seconds) by cutting them in half so that they correspond to a circle with a one unit radius.
- (e) Finally, prepare a decimal version of Varāhamihira’s table which we can use to check his values against values computed with a calculator. Begin a new table by translating the 16 arcs/angles from degree/minute form into decimal degrees to fill a first column of Angles. Then, in the next column of this table, convert the Sines we found from Varāhamihira’s values in part (d) into decimal quantities as well. Finally, in a third column, use a scientific calculator to compute the sines (lowercase s!) of the Angles in the first column to three-place accuracy. How well do the values in the second and third columns agree?
- (f) In a coordinate plane, plot the points given by the first two columns of this last table: the plot is a graph of Varāhamihira’s sine function with domain including arcs/angles up to 90° .

Task 23

In this task, we will explore what can be accomplished using Varāhamihira’s half-angle formula, from verses 3-4 above.

- (a) In Task 22(c) above, you tabulated Varāhamihira’s Sines for Arcs which are the multiples of $3^\circ 45'$, up to 60° in a circle of radius $R = 2$ units, or $120'$ (sixtieths of a unit). Recall from the table the value of $\text{Sin } 30^\circ$, then use the half-angle formula,

$$\text{Sin } \theta = \sqrt{\left(\frac{R - \text{Sin}(90^\circ - 2\theta)}{2}\right)^2 + \left(\frac{\text{Sin } 2\theta}{2}\right)^2},$$

to compute the Sine for an arc of 15° ; note that you also need the Sine-complement of arc $\theta = 30^\circ$, i.e., $\text{Cos } 30^\circ$, for this calculation, a value that already appears in the table! Do you get the same value for $\text{Sin } 15^\circ$ as you found in Task 22(c)?

- (b) Next, use the Pythagorean Theorem (see Task 20) to compute the Cosine for arc 15° and incorporate this computation into one for the Sine of arc $7^\circ 30'$ using the half-angle formula; compare also with the value you found in Task 22(c).
- (c) Repeat the procedure of part (b) to determine the Sine of the arc $3^\circ 45'$, then compare your computation with the value as you found in Task 22(c).

5 al-Bīrūnī: Trigonometry with Shadows

Roughly between the years 750 CE and 1400 CE, Islamic scholars, from their early homelands in Arabia, and later from places westward to European Spain and eastward to northern India, fostered attention to the preservation and development of mathematical and astronomical knowledge. While a list of accomplishments, even only those in mathematics, is impossible to catalog here, there are two famous advances worth noting: Islamic scholars adopted the arithmetical techniques of the Hindus, using ten symbols to represent whole numbers in decimal form – what we today call Indo-Arabic numeration; and, they developed methods for a highly general sort of problem solving called algebra, which provided a powerful tool for making new mathematical advances.

Beginning in about 1000 CE, these methods migrated into Europe and influenced the development of computational methods by Western scholars for centuries to come. However, some time before this, in about the year 820 CE, a seminal work by Muḥammad ibn Mūsā al-Khwārizmī (c. 780-850 CE) was written. In Arabic it is titled *Al-kitāb al-mukhtaṣar fī ḥisāb al-jabr wa'l-muqābala*, which translated means *The Compendium on Calculation by Completion and Reduction*, and which we remember by the Latinization of one of the words in its Arabic title as *Algebra*. This work outlined general methods for solving equations for unknown quantities and fueled the growth of a whole new main branch of mathematical activity (Berggren, 2003; Katz, 1998; Suzuki, 2009).

Muslim practice requires devotion to *ṣalāt*, or daily ritual prayer, at prescribed times of day. For this and other reasons, Islamic scholars were very interested in accurate timekeeping. Thus, the study of shadow clocks was an important concern, and this helped to further developments in trigonometry in this era. To this end, we will look at a portion of a work titled *The Exhaustive Treatise on Shadows* (Kennedy, 1976), written in 1021 by the Khwarezmian³¹ scholar Abū Rayḥān Muḥammad ibn Aḥmad al-Bīrūnī (973-1048), while he was living in Ghaznī³² in the court of a Turkish sultan. Al-Bīrūnī was a polymath, and he made a name for himself as an expert in the history, geography, and religious and scientific legacy of India, where he traveled extensively, his most famous work being *A History of India* (1017).

In the excerpt we will read from *The Exhaustive Treatise on Shadows*, al-Bīrūnī addressed the mathematical relationships between the lengths of shadows cast by the Sun and its angle of elevation above the horizon.

³¹Khwarezm is a region of central Asia – today part of Uzbekistan – which was also home to the aforementioned al-Khwārizmī, the “Father of Algebra.”

³²Now a town in central Afghanistan.

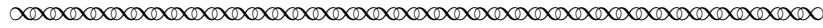

The Sixth [Chapter]: On the method by which the use of the shadow and the gnomon is arranged.

[. . .] We say that plane surfaces upon which shadows fall are numerous. They are all planes of local horizons, which will be determined if their latitudes are known. And the shadows of gnomons . . . are of two kinds, like [any] category containing its [different] types. One of the two of them is the *shadow*³³ which [. . .] is bordered by the shadow-caster and that part of the horizon plane which is between them. But since light can be perceived on the flat of the earth, a place devoid of light is called shadow, and the shadow-caster is called the *gnomon*, but when it is used, especially in computation, [it is called] the *scale*.

That sort of shadow is always in the plane of a *circle of altitude* through the shadow-caster [and cast] on the part in common between it and the plane of the horizon in the case of the vertical gnomon perpendicular to it. It is called the *extended [shadow]* because its extension is along the face of the earth which has neither protrusions nor concavities. Thus is the horizon plane; and the inclination of any other plane surface is non-zero, except for those perpendicular to it.

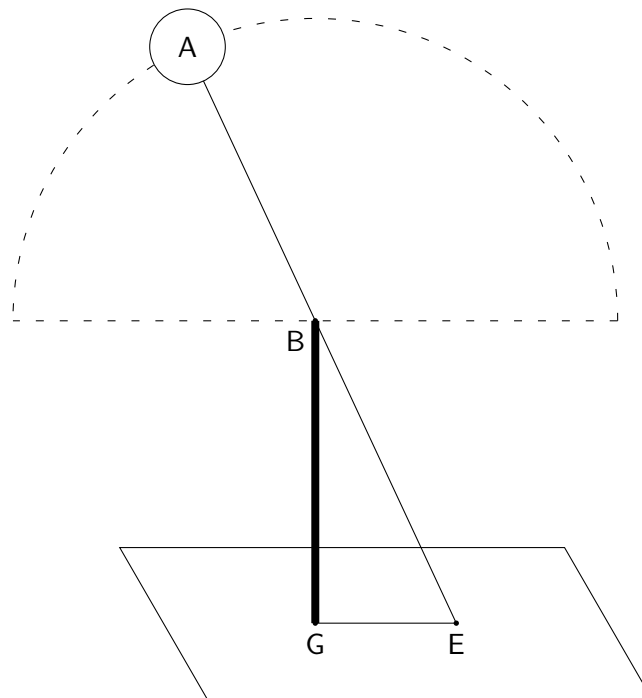

An example of the *direct shadow* is [the following (see the figure)]: Let A be the body of the sun and BG the gnomon perpendicular to EG, which is parallel to the horizon plane, and ABE is the sun's ray passing through the head of the gnomon BG. So will BGE be the shadow in space. But EG is that which is called the direct shadow such that its base is G and its end E. And EB, the line joining the two ends of the shadow and the gnomon, is the *hypotenuse of the shadow*.

³³Italics are employed here by me in this passage as emphasis to highlight important technical terms; they are not in the published translation (Kennedy, 1976).

However, as for the second type of shadow, it is that whose gnomon is [parallel to] the horizon plane. Then the gnomon is perpendicular to a plane which is itself perpendicular both to the horizon plane and the circle of altitude. And the shadow itself [accordingly] will be along the axis of the horizon. It is called the *reversed shadow* because its head is under its base, and it is called also the *erect* because it is erected along that diameter of the [terrestrial] sphere through that locality, according to this example.

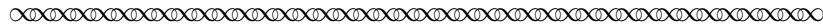
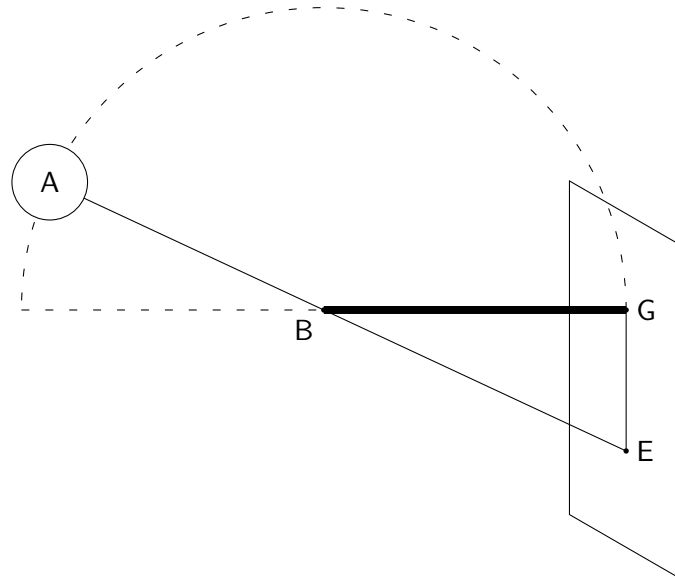

The height of the Sun, and therefore the length of the shadow it casts, at a particular time of day depends very much on the observer’s location – the “planes of local horizons” mentioned by al-Bīrūnī. The further north the observer is – the higher the location’s latitude, the lower the Sun rides across the sky, so the longer the direct shadows become (and the shorter the corresponding reversed shadows). Al-Bīrūnī is aiming to discover the technical details of this relationship between the altitude of the Sun (that is, the arc from the horizon up to the Sun along the heavenly circle through the Sun and the observer’s zenith point) and the length of the shadow that the Sun casts. The gnomon used to create the shadow will be used as a scale unit for making this measurement.

Task 24 Copy the two diagrams provided with the text. Then label these elements of the diagrams: *Sun*, *circle of altitude*, *altitude* (of the Sun), *gnomon*, *direct shadow* (in the first diagram) and *reversed shadow* (in the second).

The Sine of an arc in a circle, as identified by al-Bīrūnī and his contemporaries, is the side of the right triangle created by dropping the perpendicular from one endpoint of the arc to the radius connecting the center of the circle to the other endpoint of the arc; this is equivalent to the definition given by Varāhamihira. As the arc increases in size from spanning small angles to larger ones, the Sine also increases in length and attains its maximum length when the arc is a full quarter of the circle (for angle 90°). This largest possible Sine is called the *total Sine*, and is referred to by al-Bīrūnī at the beginning of the next passage; it is identical to a radius of the circle.

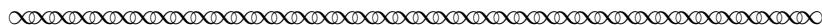

The Ninth [Chapter]: On the direct shadow and the altitude, and the extraction of one of the two from the other if [either is] unknown.

The ratio of the gnomon to the hypotenuse of the shadow is as the ratio of the Sine of the altitude to the *total Sine*.

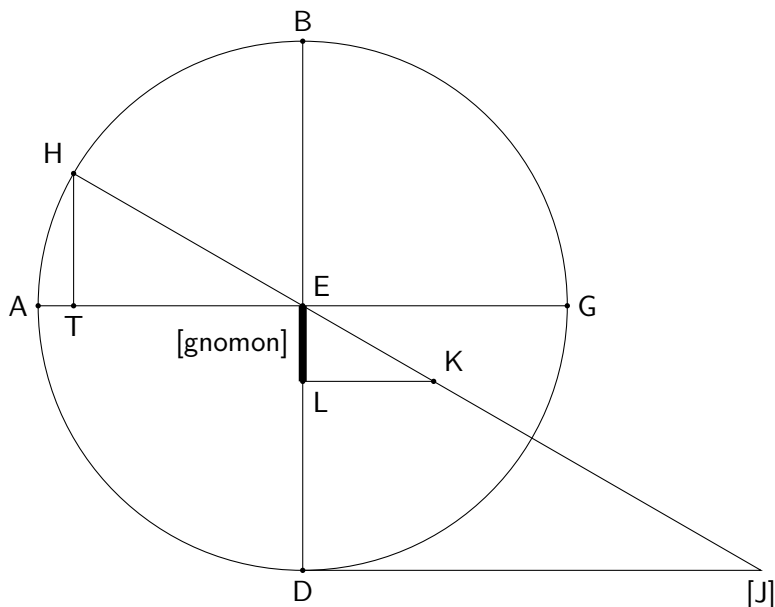

Let ABG be the circle of altitude with center E , representing the gnomon head, and AEG the common part between the plane of the horizon and the plane of this circle, and B [and] D are the two poles of the horizon.³⁴ We lay off EL equal to the gnomon, and the sun is at point H . So AH will be its altitude and the perpendicular HT is the Sine of this altitude, and HB the complement of its altitude, and ET is equal to its Sine. We extend ray HEK and LK perpendicular to EL . So LK will be the *direct [shadow]* of the altitude AH , and KE will be the *hypotenuse of the direct [shadow]*, and by virtue of the parallelism of the two lines LK [and] TE the angle HET will be the external [one] equal to the angle EKL , and the two angles T [and] L will be right angles. So the triangles EKL [and] HET will be similar, and the ratio of EL , the gnomon, to KE , the hypotenuse of the direct [shadow], will be as the ratio of HT , the Sine of the altitude, to EH , the total Sine.

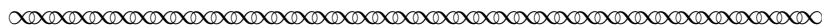

In the same way that al-Bīrūnī invokes the similarity of triangles HET and EKL in the diagram above, we notice that both triangles are similar to EJD . He could have chosen the gnomon to coincide with the radius ED (as we saw Ptolemy do earlier), in which case the direct shadow would have been DJ . Other contemporaries of his, notably Abū al-Wafā Būzhjānī (940-998 CE), set up

³⁴ B is the zenith point, directly overhead of the observer; D is the observer's *nadir*, and is the point on the celestial sphere opposite the zenith point, below the observer's feet, and not in view.

the geometry in just this way, noting that the direct shadow is now a line segment tangent to the circle, spanning an arc complementary to the given one (AH). Later mathematicians would call DJ the *Cotangent* of the arc AH (or *cotangent* with lowercase ‘c’ when the radius is a unit length). This is abbreviated as $\text{Cot } \theta$ (or $\text{cot } \theta$), where θ is the angle corresponding to the arc AH . In any case, by similarity of triangles, the ratio of the cotangent to the gnomon is the same in any of these systems.

Similarly, the hypotenuse of the direct shadow for arc AH would correspond to the segment EJ in the figure, cutting through the circle; this hypotenuse of the direct shadow would later be called the *Cosecant*³⁵ of the arc (or *cosecant* in a circle of unit radius), abbreviated to $\text{Csc } \theta$ (or $\text{csc } \theta$).

Task 25

In the passage above, al-Bīrūnī uses the similarity of triangles HET and EKL to relate the hypotenuse of the direct shadow to the Sine of the arc. Use the similarity of both of these triangles with triangle EJD to recast the assertion made at the opening of the passage as a formula that relates $\text{csc } \theta$ to $\sin \theta$. Then develop a similar formula that will relate $\text{cot } \theta$ with $\sin \theta$ and $\cos \theta$.

In the rest of the text from *The Exhaustive Treatise on Shadows*, we will follow Kennedy, the editor of the translation we are using here, and replace the terms *direct shadow* and *hypotenuse of the direct shadow* with the modern terms *Cotangent* and *Cosecant* (still reserving the lowercase versions *cotangent* and *cosecant* when working in a circle of unit radius).

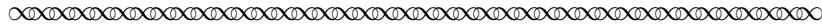

If we are given the Cotangent at a certain time, and we want to find the altitude of the sun for that time we multiply the Cotangent by its equal and we take [the square root] of the sum [with the square of the gnomon], and it will be the Cosecant. Then we divide the product of the gnomon with the total Sine by it [the Cosecant], and there comes out the Sine of the altitude. We find its corresponding arc in the Sine table and there comes out the altitude of the sun at the time of that shadow. Thus we operate for the Sine of any named arc if it is given.

[. . .] If the Cotangent is squared and the gnomon is squared and the [square] root of their sum is taken, it will be the Cosecant. . .

As for those who proceed toward the Cosine of the altitude, they multiply the assumed Cotangent by the total Sine and divide the result by the Cosecant so that there comes out for them the Cosine of the altitude, because the ratio of LK to KE is as the ratio of TE to EH, and ET is equal to the Sine of arc BH, the complement of AH, the altitude. . .

For the reverse of this, if the altitude is assumed known and the shadow of the gnomon is wanted for that time: the ratio of HT, the Sine of the altitude in the preceding figure, to TE, its Cosine, is as the ratio of EL, the gnomon, to LK, its shadow, and from this the gnomon is multiplied by the Cosine of the altitude and the result is divided by the Sine of the altitude, and the shadow results.

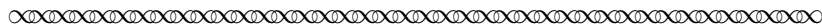

³⁵The Latin word *secare* means *to cut*.

Task 26

Suppose that “the Cotangent at a certain time” is twice the length of the gnomon. Follow al-Bīrūnī’s directions to “multiply the Cotangent by its equal and . . . take [the square root] of the sum [with the square of the gnomon]” to obtain the Cosecant, then “divide the product of the gnomon with the total Sine” by this Cosecant. The result is “the Sine of the altitude.” Now “find its corresponding arc in the Sine table,” or more simply, consult Varāhamihira’s table (Task 22(e)); “there comes out the altitude of the sun at the time of that shadow.” How high is the Sun off the horizon at this time?

Task 27

- (a) Translate the second paragraph in the last passage above into a formula relating $\cot \theta$ and $\csc \theta$, adopting the convention that the gnomon has unit length.
- (b) Translate the third paragraph in the passage above into a formula relating $\cos \theta$ with $\sin \theta$, $\cot \theta$, and $\csc \theta$, again assuming that the gnomon has unit length.

Task 28

Refer to the final paragraph in the passage above. If the altitude of the Sun is known to be $37.5^\circ = 37^\circ 30'$, use Varāhamihira’s table to find the corresponding sine and cosine values. Then follow al-Bīrūnī’s instructions to work out how many gnomon lengths the corresponding shadow of the Sun should measure.

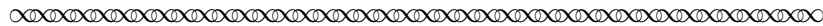

The Eleventh [Chapter]: On the [qualities] common between the two types of shadow, and their relations, and the extraction of one from the other.

The very same shadow will be a Cotangent of one arc and the Tangent of its complement. That is that line AEG, if it were in the surface of the horizon, the zenith would be point B and the altitude AH, and LK would be the Cotangent of the gnomon EL. But if one computes with point A as the zenith and with line BED in the surface of the horizon, the altitude would be BH, and the gnomon EL parallel to the horizon, and [L]K would be the Tangent of the altitude BH, and LK the Cotangent of arc AH and the Tangent for arc BH. . .

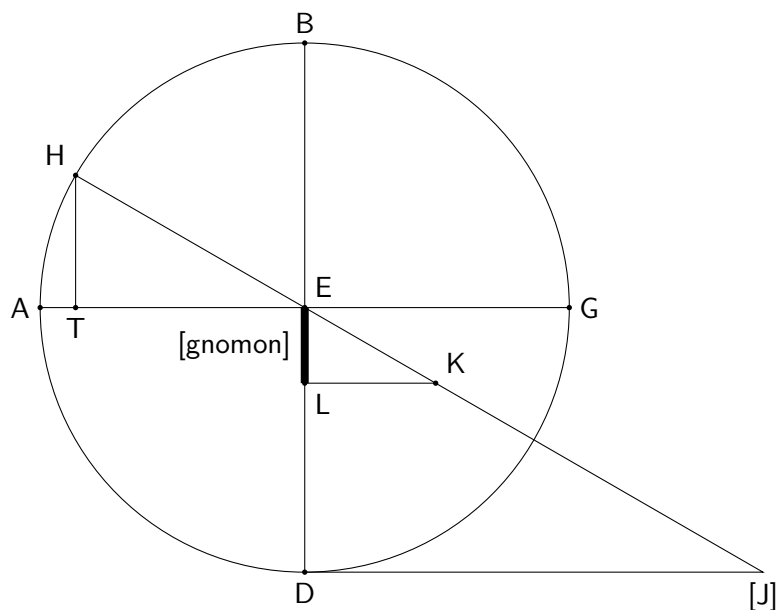

And so the square of the gnomon will be equal to the product of the Cotangent and the Tangent of the same arc. . .

Hence if one of the two kinds of shadow is known to us for an assumed arc, it is possible for us to ascertain from it the other by dividing by the known one of the two, whether the Cotangent or the Tangent, the product of its gnomon by itself, and extracting the other, the unknown, in units of the divisions of that gnomon.

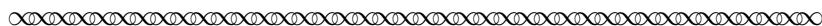

In this passage, al-Bīrūnī explains that, as the Cotangent of an arc represents the direct shadow of that arc, then its *Tangent* represents the reversed shadow (see Task 23); equivalently, *the Cotangent is the Tangent of the complementary arc*. In the same way, since the hypotenuse of the direct shadow represents the Cosecant of the associated arc, so the hypotenuse of the reversed shadow represents the *Secant* of the associated arc; equivalently, *the Cosecant is the secant of the complementary arc*. Of course, we will also refer to the tangent and secant of the angle θ (with lowercase initial letters) as in modern usage, and write $\tan \theta$ and $\sec \theta$, respectively, when the radius of the underlying circle has unit length.

Modern trigonometry has today become the study of these six functions of a real variable – the sine, cosine, tangent, cotangent, secant and cosecant functions, whose input quantities are often (but not always) viewed as angle measures. It investigates the algebraic and graphical behavior of these functions and the interrelations they have with each other.

Task 29

Adapt the result of Task 25 to give formulas that relate $\tan \theta$ and $\sec \theta$ to $\sin \theta$ and $\cos \theta$. Use these formulas to verify al-Bīrūnī’s statement that “the square of the gnomon will be equal to the product of the cotangent and the tangent of the same arc.”

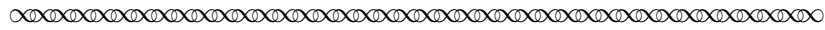

The Twelfth [Chapter]: On tables containing shadows, exclusive of their computation, and how to obtain them.

It is customary among authors of $zīj$ ³⁶ to put the values of the shadows corresponding to their arcs in tables arranged part by part, and this arrangement is befitting it, and this is how we put them.

[for the] cotangent	[for the] tangent	parts [sixtieths]
1	89	[3437; 22]
2	88	[1718; 11]
3	87	[1144; 52]
4	86	[858; 2]
5	85	[685; 43]
6	84	[570; 52]
7	83	[488; 40]
8	82	[426; 15]
9	81	[378; 49]
10	80	[340; 17]
11	79	[308; 40]
12	78	[282; 17]
13	77	[259; 54]
14	76	[240; 39]
15	75	[223; 55]
...
90	0	[0; 0]

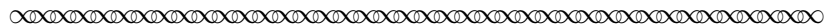

Al-Bīrūnī provides a table, or using his jargon, a $zīj$, that records the lengths of both direct and reversed shadows (cotangents and tangents, respectively) for arcs between 1° and 90° ; we only display the beginning of the table here, for arcs up to 15° . The lengths that appear in the final column are in sixtieths of the gnomon length. So, for instance, the tangent of an arc of 82° is given as [426; 15], or $426 + \frac{15}{60} = 426.25$ sixtieths of a gnomon unit. Division of this by 60 shows that it corresponds to roughly 7.1 times the gnomon unit. The reader can easily check with a scientific calculator that $\tan(82^\circ)$ is indeed roughly equal to 7.1.

Task 30

Verify that al-Bīrūnī's values for $\tan(75^\circ)$, $\tan(80^\circ)$, and $\tan(85^\circ)$ are close to the more accurate values you will obtain from a scientific calculator.

³⁶The Arabic word $zīj$ refers to a numerical table used by astronomers to assist in calculations.

Task 31

Suppose that the elevation of the Sun is 15° above the horizon; according to al-Bīrūnī's table, how long will the shadow cast by a 1 meter long gnomon be?

6 Regiomontanus: the Beginnings of Modern Trigonometry

Johannes Müller von Königsberg (1436-1476) was born just outside the town of Königsberg (located in Lower Franconia in central Germany) and studied as a young man at the universities in Leipzig and Vienna. At Vienna he became the student of Georg Peurbach, a mathematician and astronomer who gained prominence through his association as court astrologer for King Ladislas V of Bohemia and Hungary. Müller worked closely with his teacher for the rest of his life. He wrote in Latin, as did most European scholars of the day, signing his works as *Ioannes de Monte Regio*, the Latinized form of his name (both Königsberg and *Monte Regio* meaning King's Mountain); a later writer would refer to him by the name Regiomontanus, by which he has been generally known since (Katz, 1998; Van Brummelen, 2009).

Through Peurbach's connections, Regiomontanus was given the opportunity to travel across Europe in the company of Cardinal Johannes Bessarion, legate to the pope and himself a great scholar; this allowed Regiomontanus access to the most prominent thinkers of his day and to some of the best libraries on the continent. After Peurbach's death, Regiomontanus completed an edition of Ptolemy's *Almagest* that his teacher had begun. In the process he became acquainted with works by Arabic scholars in trigonometry and decided that a systematic account of that subject in support of the needs of astronomers ought to be made. To that end he wrote *De triangulis omnimodis* (*On Triangles of Every Kind*), a work in five Books, in 1464; we will next consider some selections from Book I of *On Triangles* (Hughes, 1967).

It is important to keep in mind that Regiomontanus envisioned his work in the same tradition of Greek mathematics to which Ptolemy (and Archimedes and Euclid before him) contributed. This is evidenced by how his results are listed as theorems, and supplied with geometrical proofs. Nonetheless, Regiomontanus is writing for astronomers, so he takes pains to elucidate how his theorems apply to the calculation needs of working astronomers.

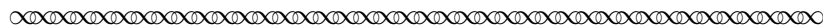

Theorem 20. In every right triangle, one of whose acute vertices becomes the center of a circle and whose [hypotenuse is] its radius, the side subtending this acute angle is the right sine of the arc adjacent to that [side and] opposite the given angle, and the third side of the triangle is equal to the sine of the complement of the arc.

If a right triangle ABC is given with C the right angle and A an acute angle, around the vertex of which a circle BED is described with the hypotenuse – that is, the side opposite the largest angle – as radius, and if side AC is extended sufficiently to meet the circumference of the circle at point E, then side BC opposite angle BAC is the sine of arc BE subtending the given angle, and furthermore the third side AC is equal to the right sine of the complement of arc BE.

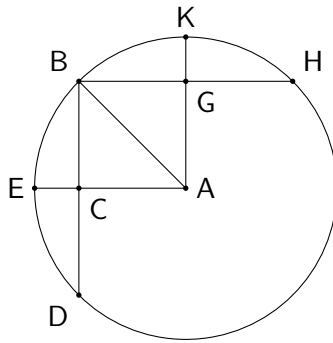

[...]

Theorem 27. When two sides of a right triangle are known, all the angles can be found.

If one of the given sides is opposite the right angle, that is sufficient; if not, however, we will find it also, by the preceding theorem³⁷, for without it it will not be possible to handle the theorem.

Thus, if triangle ABC is given with C a right angle and sides AB and AC known, then all the angles can be found.

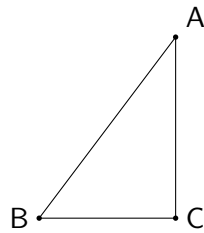

When a circle is described with angle B, which the given side [AC] subtends, as center and side BA as radius, then, by Thm. 20 above, AC will be the sine of its adjacent arc, which is opposite the angle ABC that we seek. . . Through the table of sines, by whose neglect we can accomplish nothing in this theorem, we also ascertain the arc. Moreover, when the arc for this sine is known, the angle opposite this arc is also given. . . Therefore all the angles of our triangle have been found. Q.E.D.

The mechanics: Take the value of the side subtending the right angle as the first number, and take the value of the side opposite the desired angle for the second number, while the value of the whole sine³⁸ is the third number. Then multiply the second by the third and divide the product by the first, for the sine of the arc opposite the desired angle will result. From the table of sines you may determine that arc, whose value equals the desired angle. If you subtract this [angle] from the value of a right angle, the number that remains is the second acute angle.

³⁷His Theorem 26 states that *If two sides of a right triangle are known, the third is directly apparent.* Regiomontanus' justification is straightforward: he uses the Pythagorean Theorem to determine the missing side of the triangle.

³⁸Recall that the whole sine – what al-Bīrūnī called the total sine – is the maximum sine value in the user's sine table, and corresponds to the sine given to a 90° angle.

For example, if AB is 20, AC 12, and BC 16, and the whole sine found in our table³⁹ is 60000, then multiply 60000 by 12 to get 720000, which, divided by 20, leaves 36000. For this sine the table gives an arc of approximately $36^\circ 52'$. This amount is angle ABC , which subtracted from 90, finally yields about $53^\circ 8'$, the size of the other acute angle.

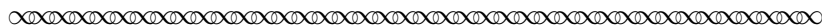

The final two paragraphs of the passage above (following the statement and proof of Theorem 27) are labeled by Regiomontanus “The mechanics.” In them he illustrates the theorem by way of a specific example.

Task 32

- (a) In the first of the two “mechanics” paragraphs, Regiomontanus describes a procedure for finding “the sine of the arc opposite the desired angle” at B . Express this procedure in the form of a formula for $\text{Sin } B$ involving the side AB , the side AC , and the “whole sine” $\text{Sin } 90^\circ$.
- (b) In the second of these paragraphs, Regiomontanus gives the dimensions of triangle ABC . Is this actually a right triangle? How can you tell?
- (c) Regiomontanus then indicates that in his table of sines the “whole sine” is 60000. This corresponds to choosing a circle not with radius 60 parts, but 60000 parts. (Scaling up by a factor of 1000 allows higher accuracy in computation: under this scheme, more digits of the target values are kept.) Apply your formula from part (a) to verify that $\text{Sin } B = 36000$. We are using the notation Sin with a capital S to signify sines in a circle of radius 60000 parts.
- (d) Apply the procedure (or your formula from (a)) to determine $\text{Sin } A$.

Task 33

A scientific calculator will compute the sine, cosine, and tangent of any desired angle, based on a standard circle of radius 1 unit. In this situation, the “whole sine” has the value $\sin 90^\circ = 1$. We continue to use \sin (with lowercase s) to signify sines in a circle of radius 1. Adapt the formula from Task 32(a) to one which replaces Regiomontanus’ sines with modern sines (in a circle of radius 1). Then use it to determine the values of $\sin B$ and $\sin A$.

In the final paragraph in the passage above, Regiomontanus does a *reverse* lookup in his table of sines: he searches for 36000 in the column of Sine values and finds that it appears as the sine of the angle $36^\circ 52'$. This, then, is what he determines the measure of angle ABC to be. We can do the same using a scientific calculator, which computes the *inverse sine* of some quantity x (denoted $\sin^{-1} x$), *inverse cosine* ($\cos^{-1} x$), and *inverse tangent* ($\tan^{-1} x$), often using the same buttons as for sine, cosine, and tangent. For instance, we have seen (Task 18) that $\sin 30^\circ = 0.5$; thus, the inverse sine of $\frac{1}{2}$ (i.e., of 0.5) must be 30° , that is, $\sin^{-1} 0.5 = 30^\circ$.

³⁹Regiomontanus’ own table of sines was not published with the first printed edition of *On Triangles*; it only arrived with the second edition in 1561.

Task 34

Verify with a calculator that the inverse sine of the two sine values you found in Task 33 give the same angles that Regiomontanus determines at the end of the passage above.

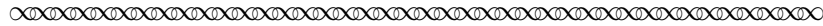

Theorem 29. When one of the two acute angles and one side of a right triangle are known, all the angles and sides may be found. [...]

For instance, let angle ABC be given as 36° and side AB as 20 feet. Subtract 36 from 90 to get 54° , the size of angle BAC . Moreover, from the table of sines it is found that line AC is 35267 while BC is 48541 (when AB , the whole sine, is 60000). Therefore, multiplying 35267 by 20 yields 705340, which when divided by 60000, leaves about $11\frac{45}{60}$. Thus, side AC will have 11 feet and $\frac{45}{60}$ – that is, three-fourths – of one foot. Similarly multiply 48541 by 20, giving 970820, which when divided by 60000, leaves about 16 [feet] and 11 minutes,⁴⁰ the length of side BC .

But if side AC is taken as 20 and everything else stays the same, AC will be 35267 and BC 48541 (when AB , the sine of the quadrant, is 60000). Thus, to find AB , multiply 60000 by 20, producing 120000, which is divided by 35267, leaving about 34 and 2 minutes. But if it is agreed to measure side BC , multiply 48541 by 20, producing 970820, which when divided by 35267, leaves about 27 and 32 minutes. Therefore, side BC is about 27 [feet] and 32 minutes of one foot.

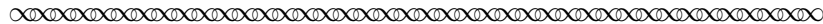
**Task 35**

- (a) Draw a diagram of Regiomontanus' triangle ABC and label the known angles as they appear in the text in the next-to-last paragraph above; he gives the hypotenuse as 20 feet. Now redraw the triangle but assign the hypotenuse, or "whole Sine," length 60000; the angles are as before, but the sides correspond to the Sines of the opposite angles. Regiomontanus states those values in the text, so transfer them to this second diagram. Show using appropriate proportions how he finds the lengths $AC = 11\frac{45}{60}$ and $BC = 16\frac{11}{60}$ for the smaller triangle (the one with $AB = 20$).
- (b) Since we don't have access to Regiomontanus' table of sines, we will use a calculator's values and modern sines to verify these values. Draw a third version of triangle ABC with the same angles, but set the length of the hypotenuse as 1 unit. Using your calculator, compute sines, rounding to five decimal places, to determine the lengths of the sides in this third diagram. Now work proportionally from this third triangle back to the first triangle to test that Regiomontanus' Sines correspond to the ones found via your calculator.
- (c) Repeat the analysis of parts (a) and (b) for the example given in the last paragraph of text above. How well do Regiomontanus' Sine values compare to your calculator's sines?

⁴⁰In this context, one minute means one sixtieth of a foot, so 11 minutes is $\frac{11}{60}$ feet.

References

- J. L. Berggren. *Episodes in the Mathematics of Medieval Islam*. Springer, New York, NY, 2003.
- Barnabas Hughes, O.F.M. *Regiomontanus: On Triangles*. University of Wisconsin Press, Madison, WI, 1967.
- Victor Katz. *A History of Mathematics: an introduction*. Addison Wesley, Reading, MA, second edition, 1998.
- Victor Katz, Annette Imhausen, Eleanor Robson, Joseph W. Dauben, Kim Plofker, and J. Lennart Berggren. *The Mathematics of Egypt, Mesopotamia, China, India, and Islam: a Sourcebook*. Princeton University Press, Princeton, NJ, 2007.
- E. S. Kennedy. *The Exhaustive Treatise on Shadows, by Abū Rayḥān Muḥammad ibn Aḥmad al-Bīrūnī*. Institute for the History of Arabic Science, Aleppo, Syria, 1976.
- Otto Neugebauer and David Pingree. *The Pañcasiddhāntikā of Varāhamihira*. Munksgaard, Copenhagen, Denmark, 1970/1972.
- John North. *The Fontana History of Astronomy and Cosmology*. Fontana Press, London, 1994.
- Olaf Pedersen. *A Survey of the Almagest, with annotation and new commentary by Alexander Jones*. Springer, New York, NY, 2011.
- Kim Plofker. *Mathematics in India*. Princeton University Press, Princeton, NJ, and Oxford, 2008.
- E. G. Richards. *Mapping Time: the calendar and its history*. Oxford University Press, Oxford, 1998.
- Jeff Suzuki. *Mathematics in Historical Context*. Mathematical Association of America, Washington, DC, 2009.
- G. J. Toomer. *Ptolemy's Almagest*. Princeton University Press, Princeton, NJ, 1998. Translated and annotated by G. J. Toomer; with a foreword by Owen Gingerich.
- Glen Van Brummelen. *The Mathematics of the Heavens and the Earth: the early history of trigonometry*. Princeton University Press, Princeton, NJ, and Oxford, 2009.

Notes to Instructors

This project was designed to serve students as an introduction to the study of trigonometry, providing a context for the basic ideas contained in the subject and hinting at its long history and ancient pedigree among the mathematical sciences. The project is not meant to substitute for a full course in the subject, as many standard topics are not treated here at all. For example, not treated at all in this project are the following topics: angle measure outside the range from 0° to 180° ; radian measure; graphs of the tangent/cotangent or secant/cosecant functions; periodic behavior; or any but the most basic algebraic identities. Rather, it is the author's intent to show students that trigonometry is a subject worthy of study by virtue of the compelling importance of the problems it was invented to address in basic astronomy in the ancient world. The author recommends that instructors use this project (or portions selected from it) in concert with a more thorough treatment of modern topics for their students.

Of particular note, instructors should recognize that in the ancient world, chords and sines were line segments associated with circular arcs, not numerical outputs of functions whose inputs were angle measures. This is a modern view. The author has found that students who are new to the idea of a mathematical function are likely to respond better to the ancient view, as it is more concrete! Also, the notation used in this project distinguishes between sines, cosines, etc., which are line segments in circles having unit radius, and Sines, Cosines, etc., which are line segments in circles having non-unit radius. The capitalization of the latter terms helps students to properly identify the standard trigonometric quantities in later work (as the geometric interpretation of the modern sine necessitates working in the unit circle) as well as to highlight the underlying geometry of the circles they will find in the texts they read for the project.

There are many ways in which instructors may employ this project in their classroom. The full project, or selections from it, may be incorporated into a standard course in College Algebra with Trigonometry, a stand-alone Trigonometry course, or a Precalculus course. In any case, the key to success is to have students read through relevant sections of the project before any class period during which the project will be used. The author has had success in focusing class time on having students work in small groups (of 2-4 students) on the Tasks provided in the project materials, with the instructor acting as a "shepherd" to encourage, redirect, and monitor the progress of the working groups. From time to time, the instructor can interrupt the entire class to make helpful comments if many groups are struggling with similar problems.

If one wishes to have students work through the entire project, the instructor should probably set aside about four weeks of class time in a course that meets three hours per week. However, the author has successfully led students through a reading of the entire project in a two-week period under a plan that made use of a bit fewer than half of the 35 student Tasks (see below). A typical 50-minute class period should be enough time for student groups to make substantial progress on 3-5 Tasks, or 4-6 in a 75-minute period. So instructors can plan accordingly how to pace themselves through the project materials.

The central features of the project are the primary source texts and the sequence of Tasks that accompany them. While individual sections of the project were not initially designed to be used independently – there are some dependencies of later Tasks on the completion of earlier ones – the following list should help instructors plan their progress through the six sections: Section 1 (4 Tasks); Section 2 (6 Tasks); Section 3 (6 Tasks); Section 4 (7 Tasks); Section 5 (8 Tasks); Section 6 (4 Tasks).

It is recommended that students complete write-ups of their solutions to the more important

or longer Tasks that they begin work on in class as homework (whether assigned daily or weekly). It should be emphasized that student written work should be far more explicit and detailed in its production than the oral communication in which they engage in the classroom, communication that is often accompanied by the recording of rather telegraphic notes.

For instructors who want an abbreviated version of the project, filling just two weeks of class time, the author suggests that students read in advance the entire project, and that instructors assign the following sequence of Tasks: #2, 5, 6, 7, 10, 16, 17, 19, 20, 21, 22, 25, 27, 29, 32 (with other Tasks selected as appropriate and done only as homework).

LaTeX code of this entire PSP is available from the author by request to facilitate preparation of ‘in-class task sheets’ based on tasks included in the project. The PSP itself can also be modified by instructors as desired to better suit their goals for the course.

Acknowledgments

The development of this project has been partially supported by the National Science Foundation’s Improving Undergraduate STEM Education Program under Grants No. 1523494, 1523561, 1523747, 1523753, 1523898, 1524065, and 1524098. Any opinions, findings, and conclusions or recommendations expressed in this project are those of the author and do not necessarily reflect the views of the National Science Foundation.

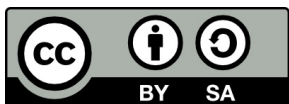

With the exception of excerpts taken from published translations of the primary sources used in this project and any direct quotes from published secondary sources, this work is licensed under a Creative Commons Attribution-ShareAlike 4.0 International License (<https://creativecommons.org/licenses/by-sa/4.0/legalcode>). It allows re-distribution and re-use of a licensed work on the conditions that the creator is appropriately credited and that any derivative work is made available under “the same, similar or a compatible license.”

For more about TRIUMPHS, visit <https://blogs.ursinus.edu/triumphs/>.